



HUMAN POWERED VEHICLE (HPV) & ENERGY EFFICIENT VEHICLE (EEV) SPECIFICATIONS

[Version 2024.01](#)

Coordinators: Michael McTigue and Tim White

Introduction

- These vehicle specifications cover the HPV Primary, HPV Secondary, EEV and Tryathlon categories at the Energy Breakthrough.
- All EEV vehicles must also comply with the 'EEV Specifications Supplement' at the end of this document.
- [Any significant specification changes from previous editions been highlighted and underlined in blue.](#)
- **Key specifications that the Scrutineers wish to bring to the attention of Team Manager's have been highlighted in bold.**
- If changes are made to these specifications prior to the event, Team Managers will be notified via email and a new edition will be published on the website.
- The Scrutineers have the final authority to decide if any vehicle or team participates in the event, based on safety and their interpretation of the following rules.
- All enquiries regarding HPV and / or EEV Specifications should be emailed to technical@eb.org.au

1. SCOPE & CONFIGURATION

1.1 Intent

The Energy Breakthrough is intended as an experiment in personal mobility. The objective is to build an efficient and stable machine powered either entirely by human effort (Human Powered Vehicle (HPV)) or a combination of power sources (Energy Efficient Vehicle (EEV)).

To support students learning, entrants are encouraged to:

- Participate in the design and construction of the vehicle whether it is from a clean sheet or the modification of an existing vehicle.
- Understand the fundamental design and construction elements of the vehicle.
- Liaise with local industry or community groups to design and build a machine.

1.2 Seating Capacity, Wheels

The vehicle shall carry a rider alone and shall have three or more load bearing wheels arranged in a stable configuration.

1.3 Riding Position

- The riding position shall not compromise machine control or safety, nor shall the riding position place the rider in a potentially hazardous position in the event of a collision.
- A prone riding position, or horizontal riding position is not permitted.
- It is not advisable for the bottom bracket to be higher than the rider's heart.

1.4 Power Source

HPV

Motive power shall be entirely supplied by the rider.

EEV

- See EEV Specifications Supplement.

1.5 Maximum Speed

- The maximum speed of vehicles shall be 60 km/h. The Trial is a test of endurance and efficiency and therefore vehicles should not be designed to achieve extremely high speeds.

2. DESIGN AND MATERIALS

2.1 Inherent Safety

- The design shall provide protection for the rider in the event of a collision or rollover.
- The design must be free of protrusions or other features capable of causing interference or injury to fellow competitors or spectators.
- Vehicle control and stability shall not be jeopardised by inappropriate design and construction methods.
- The onsite repairing, securing or joining of steering, brake or any other safety related components with glue or epoxy resins during the event, must be carried out in the specified repair area, with an event scrutineer present.

The cockpit must be free of hazards that could injure the rider or pit crew. For example:

- Zip tie ends need to be cut flush, filed round, taped over or rotated away.
- Brake and gear cable ends should be covered with cable caps.
- No bare edge, rigid material shall be within 250 mm of the rider's face.

2.2 Exclusions

Choice of design and construction materials is free, except that:

Designers and constructors are permitted to freely use any bicycle component except for complete frame sections.

- The use of Go-Kart frames or motorbike frames is not permitted.
- Maximum overall tyre width is 70 mm.
- Rope, cable, tilt, lean steering systems and flexible steering columns are prohibited.

3. VEHICLE DIMENSIONS & TURNING CIRCLE

Length

2800 mm maximum

Width

1100 mm maximum

Height

1200 mm maximum

Wheelbase

1000 mm minimum wheelbase between the most forward and most rearward axles.

Track

600 mm minimum (width between centres of outermost tyre ground contact points)

Teams wishing to construct a four wheeled vehicle are required to meet the following track dimensions:

- One of the vehicles track widths must be a minimum of 500mm.
- The sum of both axle's tracks is to be 900mm minimum.

Turning circle

It is recommended that **HPV Primary, HPV Secondary and EEV vehicles** can meet a 12 metre turning circle.

It is recommended that **Tryathlon HPVs** can meet an 8 metre turning circle. This is due to the two hairpins in Tryathlon Obstacle course.

4. VEHICLE WEIGHT

HPV

50kg maximum

EEV

Single Power Source 60kg maximum

Hybrid 1 60kg maximum

The EEV specified maximum weight includes batteries.

Notes:

- All vehicles will be weighed as part of Scrutineering.
- EEV teams are encouraged to make their vehicles as lightweight as possible without compromising safety.

5. BODYWORK

5.1 Bodywork configurations

There are three bodywork configurations, which impact the structure of the vehicle:

1. Open bodywork (or 'head out') vehicles requiring full roll bar protection.
2. Aerodynamically enclosed vehicles with a soft shell or corflute panels requiring full roll bar protection.
3. Fully enclosed hard-shell bodywork vehicles built from a stiff composite material. (ie. carbon fibre / kevlar / fiberglass)

Note:

The test for whether a vehicle will be accepted as a fully enclosed hard-shell is if the roof is able to support the weight equivalent to a rider between the rider's head and their knees. If the roof is unable to support this weight it will be deemed 'aerodynamically enclosed' and must meet all roll bar requirements.

5.2 Multiple configurations and removal

- If teams prepare multiple bodywork configurations for use, then all configurations must comply with all specifications and must be presented for approval during Scrutineering.
- Bodywork must not be removed Practice Sessions and the Trial; between Tryathlon events; or during the Trial if doing so compromises occupant safety. (i.e. Removal of the roof in hard shell vehicles.)

5.3 Access for Enclosed Bodywork Vehicles

- The rider shall be able to open and/or remove bodywork and exit the vehicle without external assistance.
- Bodywork shall be capable of being easily opened and or removed from outside the vehicle independently of the rider by someone who is unfamiliar with the vehicle. In an emergency marshals must be able to open the vehicle without explanation.
- The location of closure devices for opening body sections must be marked outside with a triangle of contrasting colour to the body and side length of at least 100 mm making it clear for anyone unfamiliar with the vehicle. If a hole has been cut in a window to enable access to an elastic strap then the hole must be able to allow for an adult hand to easily reach into the vehicle.

5.4 Bodywork Clearance

There must be a forward clearance of at least 300 mm between the rider's face and any bodywork.

5.5 Vision

- Rider vision must not be impaired by excessively enclosed and restricting bodywork
- Side windows must be incorporated in the vehicle body design and must extend from the shortest rider's shoulder line to above and behind the tallest rider's eye line. Riders must have a clear view over their shoulders to see surrounding vehicles.
- Windows must not be tinted or covered with any stickers, regardless of if they are intended to be see-through.
- Windows must allow marshals to monitor designated riders and correct riding apparel during the Practice Sessions and Trial.

5.5.1 Vision Tests

The shortest rider and the tallest rider seated in their normal riding position will be required to have sufficient vision to comply with the following vision tests during scrutineering:

- Sight an object on the road 5 metres in front of the vehicle.

Diagram 5.5.1A Forward Vision Test

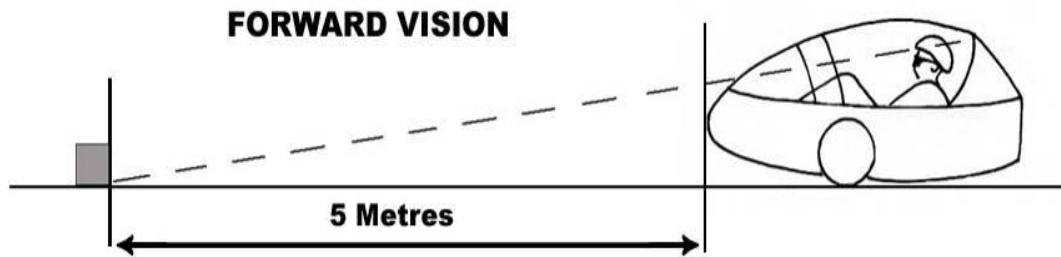
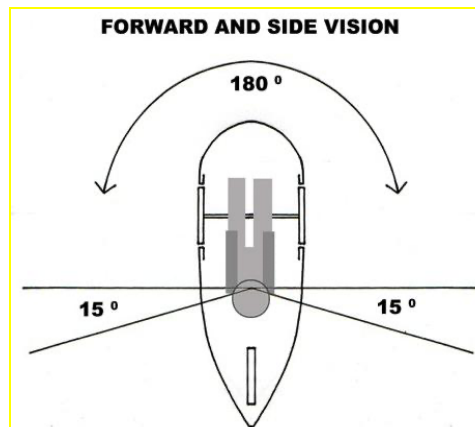

Diagram 5.5.1B Forward and Side Vision Test



- Sight 180 degrees ahead of the rider.
- Be able to turn their head sufficiently to see 15 degrees behind the rider on each side of the vehicle. The intent of this clause is that a rider is able to turn their head to visually check for other vehicles before changing their position on the road.
- Riders must be able to demonstrate that the mirrors can provide adequate rear vision.

5.6 Ventilation

- Rider and vehicle safety must not be impaired by restricted ventilation.
- Airflow for rider ventilation, provision to mitigate rain and window fogging should be considered in vehicle design.

6. RIDER PROTECTION

6.1 Bars for Open and Aerodynamically Enclosed vehicles

Open and Aerodynamically enclosed vehicles must have four sets of protection bars:

1. "Head bar" (main bar) including brace,
2. "Forward leg bar" including brace,
3. "Side intrusion bars", and
4. "Overhead protection bars".

6.2 Construction

- All protection bars, including bracing must be constructed from metal meeting the minimum outside diameter (O.D) specifications in the following table.

	HPV & EEV1	SPS
Steel or Chromoly tubing.	12.7mm O.D	16.0mm O.D
Aluminium tubing	16.0mm O.D	19.0mm O.D

- All bars except the overhead protection bar must be joined either by welding or plate method (Refer 6.9: Plate Joints)
- The overhead protection bar may be hinged and locked to enable easier access for riders.

Diagram 6.2A and 6.2B: Positioning of Protection Bars

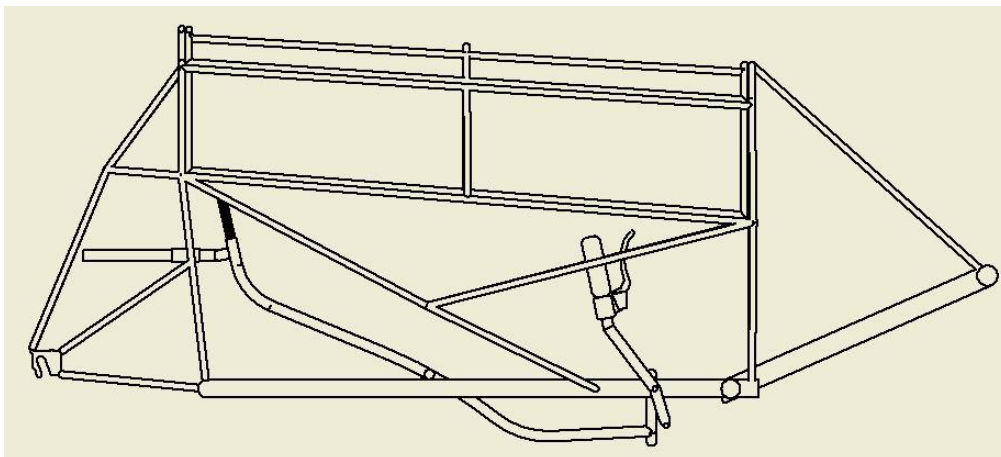
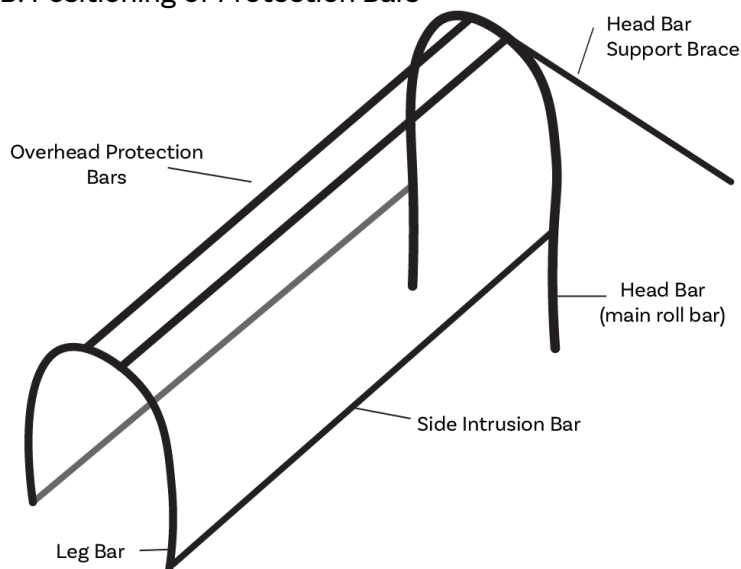

(Please note: Drawings are not to scale)

6.3 Head Bar

- The main “head bar” and brace together with the side intrusion bars must be one continuous welded frame, constructed according to Diagram 6.2A and must be solidly attached to the vehicle frame. (Refer 6.9: Plate Joints)
- The “head bar” hoop must be braced from its highest point with one bar, preferably two, to a major structural member to form a tripod.

The head bar must conform to the following dimensions:

- With the tallest of the competing riders in the normal riding position, the “head bar” must be fully visible outside the rider silhouette when viewed from the front or rear.
- Measurement from helmet to inside of bar: 100mm minimum
- Measurement from either side of helmet to inside of bar: 100mm minimum
- Clearance around rider’s body to inside of bar: 50mm minimum
- Location forward or rearward of helmet: 150mm maximum

Diagram 6.3: Head Bar clearance in open top or aerodynamically enclosed vehicles

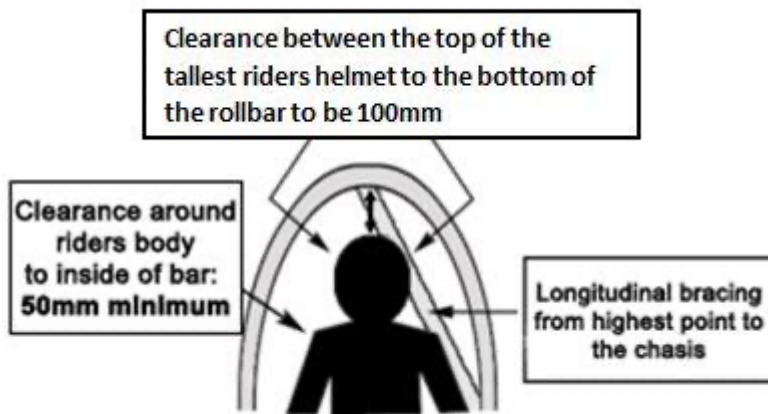

6.4 Leg Bar

- The “leg bar” must protect the rider’s legs, knees and feet from contacting the ground in a rollover or side slide situation and must be mounted across the vehicle above the riders knee area.
- The “leg bar” must be braced to prevent the bar from folding over in a rollover or sliding situation.

6.5 Side Protection

- The vehicle must have side intrusion bars typically in line with the rider’s that are an integral part of the continuous “head bar”.
- In addition to the side intrusion bars, side protection bodywork or shielding is required to protect the area between the rider’s hip and shoulder from making contact with another vehicle and to prevent the rider’s shoulders and arms from reaching the ground in the event of a rollover.
- This side protection bodywork should be constructed from suitably strong materials that will withstand sliding contact with the road.
- No part of the rider is allowed to protrude outside the side protection during normal operation.
- There must be a clearance between any part of the rider and the shielding.

Diagram 6.4: Side Impact Protection

SIDE IMPACT PROTECTION

Side protection should prevent shoulder and arm from reaching the ground in the event of a rollover

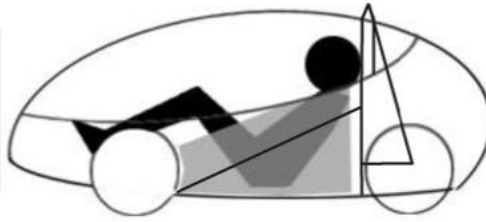

Shading denotes area to be protected from side intrusion

6.6 Overhead Protection

- The structure over the head of the rider must provide enough strength to prevent the rider's head from being struck by another vehicle when on its side after a roll over.
- Open top and aerodynamically enclosed vehicles must have two longitudinal bars connecting the main head bar to the knee bar.
- Bars must be symmetrical around the vehicle centreline and there must be 100mm to 200mm of separation between the bars.
- **The overhead protection bars must have at least 50 mm clearance above any part of the rider when viewed from the side.**
- These bars may be detachable or hinged to enable easier access for riders, but must lock in place and be strong enough to ensure the structure remains attached during a rollover.

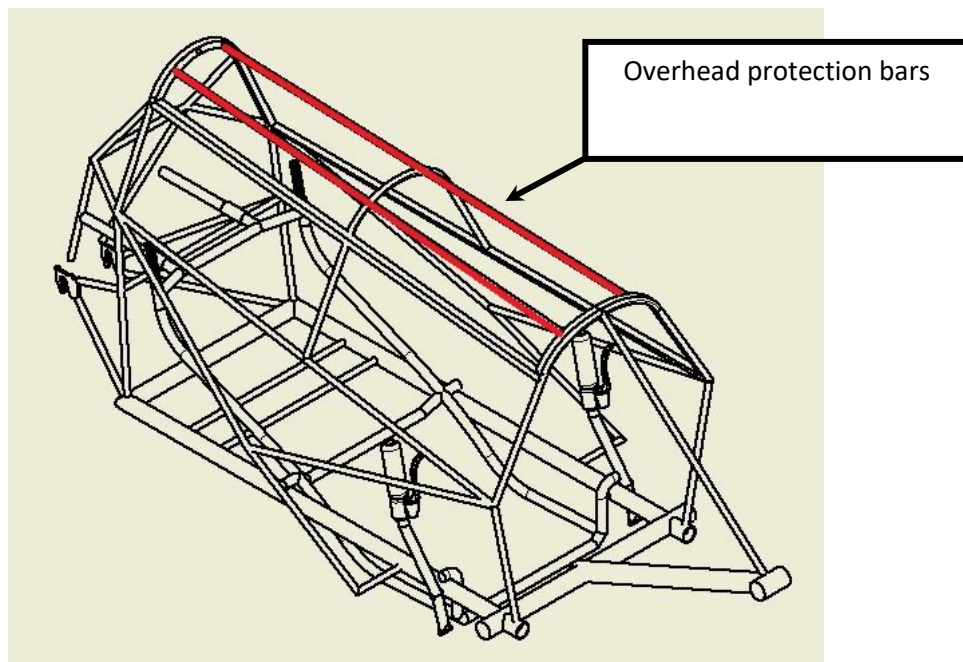

6.7 Rider protection for fully enclosed hard-shell vehicles

Fully enclosed bodies made from composites such as Carbon-Fibre, Fibreglass or Kevlar do not require metal protection bars provided they comply with the following requirements for strength and build quality tests:

- The body must have strengthened ribs moulded into the composites that are of at least equal strength to a metal roll bar. (eg: The roll bar area should not be able to flex when pressed by hand)
- All composite roll bar and side intrusion bar ribs must follow the same positioning as the metal protection bars outlined in section 6.1.
- All composite constructions must have finished edges. That is no protruding fibres or frayed edges.
- Metal roll bars can be used with composite bodies.
- Any joins must follow the plate mounting method. (Refer 6.9: Plate Joints)

Note:

- The test for whether a vehicle will be accepted as a fully enclosed hard-shell is if the roof is able to support the weight equivalent to a rider between the rider's head and their knees. If the roof is unable to support this weight it will be deemed 'aerodynamically enclosed' and must meet all roll bar requirements.
- The onus is on schools to ensure that their vehicle is compliant with the required safety standards. The Energy Breakthrough website includes some advice on composite construction.
- **All teams constructing new hard-shell composite vehicles with integral protection bars are encouraged to send photos to the technical contacts for review by the end of October.**

6.8 Rider Protection Clearances for fully enclosed hard-shell vehicles

Hard-shell vehicles are required to have a piece of Ethylene Vinyl Acetate (EVA) foam placed above the rider's head.

This foam must be:

- Of Density 105kg/cubic metre.
- Minimum 20mm thickness.
- Minimum area of 1200cm². (or dimensions of 200mm x 600mm).

Riders are required to maintain clearance between helmet and foam at all times.

Note:

it is strongly recommended that teams install additional foam protection around the rider's shoulders and arms.

6.9 Plate Joints

- Where metal protection bars are to be joined without welding or attached to a composite body, plates should be used to distribute the loads into the body.
- A matching plate should be used on either side of the composite body and spacers must be used to prevent crushing of the composite structure.
- The plates must be joined using at least two 6 mm bolts with locking nuts (eg. Nylock Nuts).

6.10 Forward Protection & Nose Cone

- All vehicles must have adequate forward protection to reduce the chance of injury in the event that the vehicle collides with a person or another vehicle.
- **The front of the vehicle must have a curved nose to prevent easy penetration of another vehicle. At 100 mm from the front, the vehicle must have a cross section greater than 200 mm.**

7. SEAT

7.1 Positioning

- The seat must be fitted in a way that ensures that the riding position does not compromise machine controllability or safety, nor shall the riding position place the rider at risk of neck or back injury in the event of a collision.
- The seat must be shaped and positioned to prevent the rider sliding under the seat belt.
- In vehicles with moveable seats, riders must remain protected by the side intrusion bars in all seat positions.

7.2 Locking of Seat Position

- The seat must be securely mounted.
- Adjustable seats must lock securely into position for each rider and must not move forward or backward.
- Seat belts cannot be used as part of the seat lock system.

7.3 Additional Padding

- Any temporary or removable padding used for riders MUST be fixed into place using a positive attachment to a fixed part of the vehicle.
- This could be a strap and buckle, velcro straps, dog clips, canvas zips, etc.

7.4 Head Restraint

The vehicle must have a padded head restraint behind the rider's head that reduces the chance of over extension of the rider's head backwards.

8. SEAT BELT

8.1 Type

- **The vehicle must be fitted with an Approved and Certified adult four point (minimum) seat belt for all riders.**
- Seat belts must have certification label attached.
- The seat belt must be in good condition and completely standard, including buckle, stitching and mounting plates.
- Teams will be required to demonstrate adjustment of the seatbelt to suit each rider.

8.2 Suggested suppliers

- Hemco Industries - <http://www.hemco.com.au/> or Ph: 1300 065 057
- APV Safety Products: 4 point, 2 inch webbing available through most automotive parts stores.

8.3 Mounting

- **The belts cannot be mounted to the seat surface alone under any circumstances.**
- The belts can be mounted through the seat to a bracket/plate/tube that is at least the strength of the seat belt mounting plate and that the strength can be traced all the way to the structural frame of the vehicle.
- Upper belts mounted behind the rider's shoulders are required to be horizontal or no more than 40 degrees from horizontal and mounted no more than 200mm apart so as not to allow the belt webbing to fall from the shoulders when riding.

8.4 Positioning

Correct and safe positioning of the belts and catches can be found in the Australian Design Rules (ADRs) for motor vehicles.

This means seat belts must:

- Be positioned such that it does not have any contact with, or rub against, any sharp edges
- Be worn over the shoulders and down the chest, to a low lap belt across the pelvis.
- Be adjusted to be as firm as possible on each rider and fitted to ensure that the seat belt remains properly adjusted on each rider at all times.
- Be adjusted with the lap belt tightened before the shoulder belts so that the lap belt remains in the correct position.

9. SHIELDING

9.1 Rider Protection

The rider must be shielded from any rotating mechanical part in the vehicle. This includes chains, sprockets and teeth, as well as wheels and tyres.

Diagram 9.1A Front Chain Guard And Sprocket Guard Examples

Rigid Chain Guard

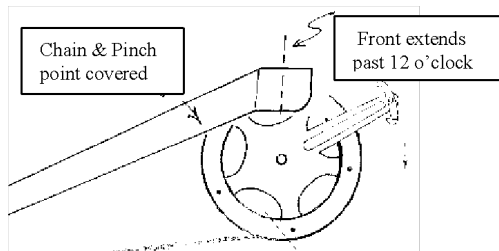

Chain Tube and Sprocket Rings

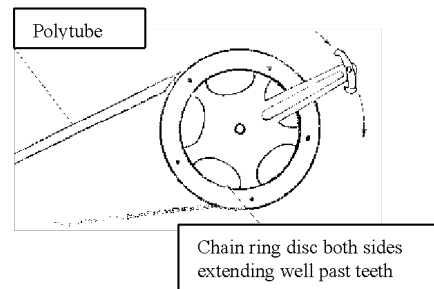

- Chains, sprockets and gears **MUST** be fully shielded to prevent accidental hazardous contact with rider or clothing.
- Chain ring teeth must be covered both sides using chain ring discs.
- A hair shield must be used to prevent long hair from falling anywhere near the rear wheel, chain or gear components.
- **All vehicles must have inner guards which completely separates the rider from the wheels. This means that the front and rear wheels and tyres **MUST** be fully shielded from the rider.**
- Wheel guards can be made using core-flute.

Diagram 9.1B Front Wheel Shielding Example:



9.2 Protection of other Vehicles

- Chains, gear wheels and sprockets shall be suitably shielded to prevent their contact with other vehicles.
- Exposed axle ends have to be recessed or flush in the hub, covered by bodywork, bar work, dome nuts or wheel covers.

9.3 Shielding from Road Surface

- Vehicles must be fitted with an under-tray or floor panel which prevents the rider's feet from contacting the ground when seated in the riding position.
- Pedal toe clips, elastic straps or pedal-to-shoe locking devices do not fulfil the requirements of this clause.

10. STEERING

10.1 Type

The type of steering mechanism is free, except for:

- Rope, cable, tilt, lean, and flexible steering columns are prohibited.
- **A minimum clearance of 300mm is required between the riders face and the steering controls.**
- The rider must have continuous positive control without the need for regular adjustment.
- Adjustable steering columns must be fitted with a secure/ positive locking mechanism, i.e. a bolt and locknut or over-centre locking clip.
- Adjustable steering columns cannot be fixed using Pins and R clips.
- Rear wheel steer vehicles can be designed and constructed by teams, provided that a submission is made to the Scrutineering team and adequate prototyping is carried out prior to the event.

10.2 Freedom from Binding and Fouling

Steering linkages shall operate freely from full left to full right lock without binding or fouling.

10.3 Lock Stops

- To prevent the rotating road wheels from coming into contact with any part of the vehicle or rider, there must be positive steering lock stops.

- The steering mechanism or any solid component that moves with the steering mechanism must come up against a solid bracket or non-flexible part of the body or frame on full lock in either direction and stop any further steering travel.

11. BRAKES

11.1 Type

- The front axle braking system shall be either drum or disc type.
- They must not act on the wheel rims.
- No brake systems should apply friction contact to the tyres.

11.2 Braking configuration

- The vehicle must have a minimum of two independently operated braking systems, both systems must be operational at all times.
- Both front wheels must have a braking capability.

Teams are free to choose from two types of braking configurations:

1. “Single Lever”: Both front wheels are operated via a single lever.
In this configuration, a rear brake IS necessary.
2. “Independent”: Both front brakes are operated via an independent braking lever (ie/ Left hand lever for left hand brake).
In this configuration, a rear brake IS NOT necessary.

Note:

Team Managers are encouraged to provide additional training opportunities for riders prior to the event for vehicles with “Independent” braking systems.

11.3 Steering Control

Full steering control shall be maintained while braking systems are being operated.

12. LIGHTING

12.1 Headlight

- Front lighting must be at least one white light, securely mounted a maximum height of 600mm above road level, at the front of the vehicle (ie. forward of the rider’s feet).
- Lighting must be adequate to provide good visibility for the rider to see the track in the dark.
- Additional lighting to improve the rider’s vision is encouraged provided at least one light meets the designated requirement.
- Headlights are not to be flashing.

Note:

Sections of the track are in darkness at night and sufficient lighting will be required to see the road.

12.2 Tail Light

Rear Lighting must be:

- a) Fitted and turned on for the duration of all on track events.
- b) Red LED colour only
- c) Set to steady mode ONLY
- d) Mounted within 150mm of the rear-most part of the vehicle.

- e) Mounted on the vertical centre line of the vehicle.
- f) Visible through 160° rear sweep.
- g) Securely mounted between 350mm and 600mm above road level.
- h) All red lights on the vehicle must be rear facing and comply with (a – g)
- i) A minimum of three LEDs

12.3 Outline Lighting

The use of reflective material or strip lighting to indicate machine width and height (especially from the rear) is encouraged.

12.4 Mounting

All lights are required to be securely mounted for the duration of the event to maintain correct aim.

12.5 Helmet Mounted Lights

Helmet mounted lights are not to be used.

12.6 Batteries

- Wet cell batteries must be housed in a sealed box (e.g. plastic) that will prevent spillage if the battery is inverted or damaged.
- All electrical connections for lights or warning devices must be of an automotive or industrial standard with fully insulated connectors.

13. MIRRORS

- At least two effective rear-view mirrors of a minimum area of 18 cm² must be fitted, one on each side of the vehicle, and having similar reflection (i.e. same size image) in order to clearly identify overtaking traffic and meet the rear vision test during Scrutineering.
- Mirrors may be of the mildly convex type.
- The smallest rider must be able to reach each mirror from the normal riding position.

14. WARNING DEVICE

- **An electronic audible warning device shall be fitted (e.g. smoke alarm siren) and operate from the normal riding position.**
- The warning device must be directed forwards and directly contact the outside airstream.
- The device must not run continuously and operate via a momentary switch.
- The warning device should be waterproofed.

15. OTHER DEVICES

- Any other equipment, e.g. drink bottle, shall be securely mounted and shall not impair rider control in its mounting or use.
- The use of MP3's or similar music /entertainment devices by riders is NOT permitted.
- Small video cameras (eg. GoPro) are allowed as long as they are not attached to the rider's helmet and are positioned so that they cannot pose any safety risk.
- Cameras should not be mounted outside the silhouette of the vehicle when viewed from the front.

16. SPEEDOMETER

- All vehicles shall be equipped with an electronic speedometer (e.g. Garmin) to monitor speed during the event (pit area speed limit of 10 kph, track speed limit of 60kph).
- This speedometer must be mounted on the vehicle in a position where the rider can see from normal riding position.
- A wristband-based speedometer worn by the rider is not acceptable.

17. TRANSPONDER

- Vehicle design should allow for a lap counting transponder to be mounted:
 - inside the vehicle
 - securely on the chassis where the chassis is metal; but with a 10mm foam or plastic spacer where the chassis is carbon fibre.
 - positioned within 200mm of the road surface
 - not within 500mm of an LED light, it's cable or power source; and
 - not within 500mm of any Radio Frequency (RF) source (ie. fans or electric motors.)
- Transponders will be issued to Team Managers upon Check-in at the Administration Centre at the event.

18. MARKINGS

18.1 School Name

Each vehicle shall have their school name visibly displayed on either side of their vehicle.

18.2 Identification Panels

- Two Identification Panels will be issued to Team Managers upon Check-in at the Administration Centre at the event.
- The adhesive identification panels measure 250mm x 300mm and have the vehicle's competition number on it.
- These identification panels must be attached to each side of the tail of the vehicle and as close to the rear as possible.

Diagram 18.2: Positioning of number panel

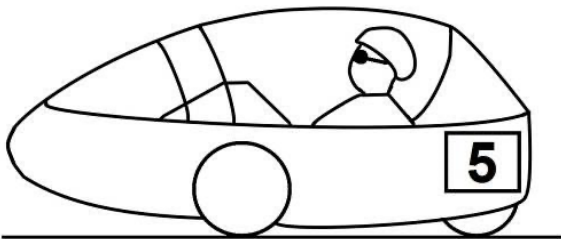

18.3 Prohibited sponsorships, logos and brands.

As a school-based, education event, entrants are prohibited from advertising products or services not suitable for young people, including but not limited to alcohol and gambling. If you have any doubts about the suitability of a sponsor, please contact us.



ENERGY EFFICIENT VEHICLES (EEVS) SPECIFICATIONS SUPPLEMENT

[Version 2024.01](#)

Coordinators: Michael McTigue and Tim White

Introduction

- Please note that all specifications listed in the Human Powered Vehicle (HPV) And EEVS (EEV) Specifications apply to Energy Efficient Vehicles with the following additional specifications.
- [Any significant specification changes from previous editions been highlighted and underlined in blue.](#)
- **Key specifications that the Scrutineers wish to bring to the attention of Team Manager's have been highlighted in bold.**
- If changes are made to these specifications prior to the event, Team Managers will be notified via email and a new edition will be published on the website.
- The Energy Breakthrough (EB) Scrutineers have the final authority to decide if any vehicle or team participates in the event, based on safety and their interpretation of the following rules.
- **From 2023 onwards, all internal combustion, fuel powered vehicles are no longer eligible to participate in the Energy Breakthrough. All EEV vehicles must use electrical propulsion.**
- All enquiries regarding HPV and / or EEV Specifications should be emailed to technical@eb.org.au

1. RIDER PROTECTION BARS

Rider protection for EEVs is the same as for Human Powered vehicles except that the metal protection bars are of greater diameter as per section 6.2 of the HPV & EEV vehicle specifications.

Note: A Human Powered Vehicle that has been converted to an Energy Efficient Vehicle will satisfy the Rider protection specifications by duplicating the minimum specified bar dimensions for an HPV.

2. FIRE EXTINGUISHERS

- All EEVs must be fitted with an Australian Standard, dry powder minimum 5BE fire extinguisher of minimum capacity 0.5 kg.
- Fire extinguishers must be securely affixed to all EEVs. The use of weak or flimsy mounting brackets and/or securing straps is not permitted.
- Fire extinguishers must be positioned such that it can be readily reached and removed for use by either the rider from the normal riding position or external assistant in an emergency.
- The location of the fire extinguisher must be clearly indicated on the exterior of the vehicle.

3. CUT-OUT SWITCH

- All EEVs are required to fit a cut-out switch that shuts down all propulsion sources and is accessible from outside the vehicle.
- The cut-out switch must be clearly visible, marked by a blue triangle and mounted on the left hand side of the vehicle and within 300 mm of the rider's left shoulder.

4. POWER SOURCES

4.1 Number of Power Sources

There are two types of vehicle class permitted in the Energy Efficient Vehicle category:

1. [Pedal-Electric Hybrid: Pedal power and Electric-power.](#)
2. [Electric Vehicles: Electric-power only.](#)

4.2 Minimum Duration of Power Generation

- Pedal assist type vehicles will be eligible to compete in the **Pedal-Electric Hybrid class**.
- While satisfying this requirement a power source may be used intermittently during the event to overcome particular loads, such as starting from rest or hill climbing.
- The spirit of this clause is that a sacrificial form of propulsion is not acceptable.

5. ELECTRICAL SUPPLY

5.1 Motor Type

Choice of motor type and gearing is free.

5.2 Total capacity and type of propulsion batteries

- Propulsion batteries shall be commercially available and not modified from their manufactured state.
- Battery packs can be placed in a casing providing that the cells are not removed from the manufacturers wrap or covering.
- Data sheets for batteries and chargers will need to be submitted to the scrutineering team prior to the event.
- Battery chargers must be commercially available and must not be modified from OEM standard.
- Batteries and chargers will be inspected and marked during Scrutineering.

5.3 Battery Casing

- Batteries with deformed or damaged cases are not acceptable for use.
- Any Lithium Ion (Li Ion) batteries with thin plastic wrapping must be housed within a protective case at all times (on and off the vehicle including when charging) to prevent puncture or damage in an accident.
- This protective case must be made of non-conductive material and preferably made of hard-plastic case with a foam padding and a lead lock.
- Wet cell batteries must be housed in a sealed box (e.g. plastic) that will prevent spillage if the battery is inverted or damaged.

Figure Ref 5.3: Battery Casing Examples



5.4 Total number of propulsion batteries

The maximum number of batteries per vehicle is:

Class	Max no. of batteries
Pedal-Electric Hybrid	4
Electric Vehicle	5

Note: Where Lithium Ion or Lithium Polymer batteries are used a Battery Management System must be carried on board that is designed to provide adequate protection during charging and discharging.

5.5 Battery Charging Allowances

The amount of power available from the grid via the EEV Container will be as follows:

Pedal-Electric Hybrid	5.0 kilowatt hours
Electric Vehicle	10.0 kilowatt hours

5.6 Mass of propulsion batteries on vehicle

- Vehicles are required to carry at least one battery pack at all times so that the electrical circuit is complete.
- Batteries must be securely mounted in vehicles.
- A battery pack is regarded as the normal quantity of batteries required for the electric motor to propel the vehicle.

5.7 Power limitations for EEV's:

- Electrical systems are restricted to a maximum of 48 Volts.
- Pedal-Electric Hybrid: it is recommended that these vehicles have a maximum motor output of 300-400 watts.
- Electric Vehicles: it is recommended that these vehicles have a maximum motor output of 650-750 watts.
- A 20 amp maximum circuit breaker or fusible link must be installed. If a circuit breaker is fitted, it must be out of reach of the rider.

5.8 Energy Meter

- All EEVs will be required to have an energy meter fitted. This device will be fitted during scrutineering.
- [This meter records and transmits energy usage data from the vehicle during the Practice and Trial.](#)
- [This data is then displayed via a publicly available dashboard via: https://results.eb.org.au/](https://results.eb.org.au/)
- [EEV Energy Meter Specifications and wiring requirements are available from 'Team Managers Hub' page on the EB website: https://www.eb.org.au/team-managers-hub/](https://www.eb.org.au/team-managers-hub/)