

EEV Energy Meter Trial 2022

Integration

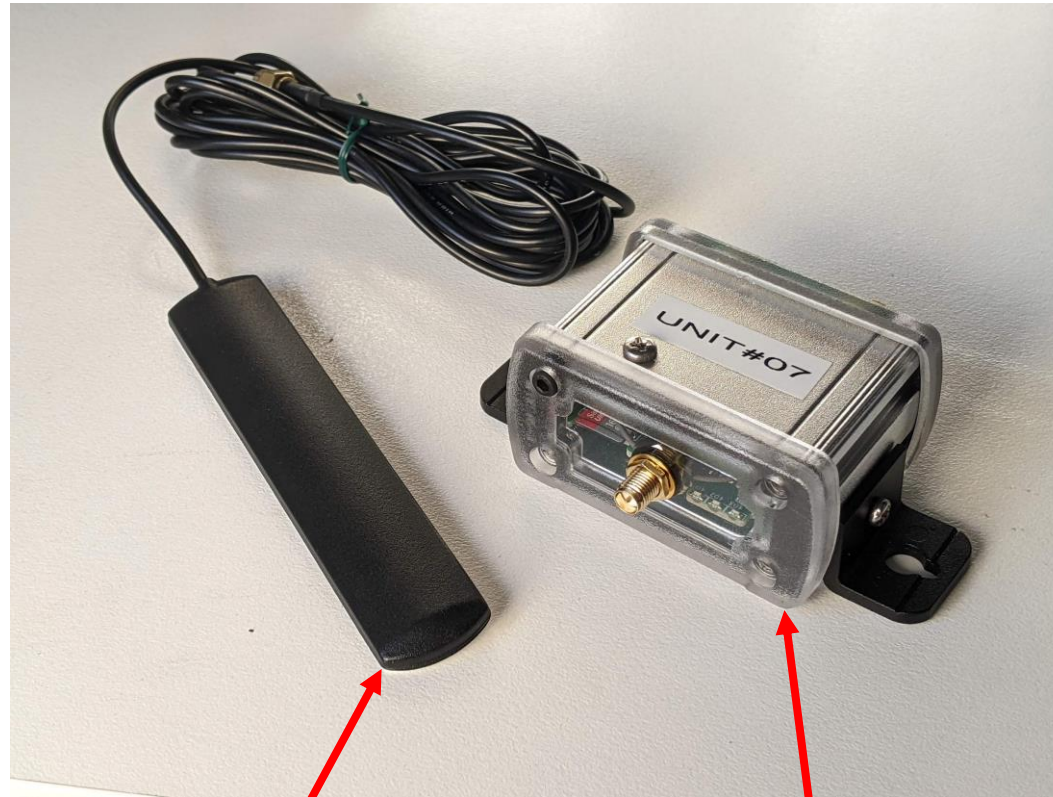

Team Kit



Windscreen Mounted
Antenna

Energy Meter

Modification to Vehicles

From Battery



To Motor



Results Page

EEV - Energy Breakthrough (2019) x +
https://www.multisportaustralia.com.au/races/energy-breakthrough-2019/events/3/
Energy Breakthrough (2019) / EEV / Overall

EEV

Pos	Name	School	Category (Pos)	Laps	Fastest	Average	Slowest	Energy	
1	XCEPTION (#1)	Girton Grammar School	SPS (1)	692	00:01:45	00:02:04	00:07:33	7.79	♥
2	EMATRIXPRO (#214)	Rode Rage	Hybrid 1 OPEN (1)	677	00:01:35	00:02:06	00:20:22	9.29	♥
3	THE T-REX WAS ANGRY BECAUSE THEY HAD SHORT ARMS (#224)	Bendigo Senior Secondary College	Hybrid 1 B/C (1)	642	00:01:44	00:02:14	00:13:22	7.43	♥
4	IN-X.S (#218)	Girton Grammar School	Hybrid 1 B/C (2)	634	00:01:45	00:02:16	00:19:54	5.86	♥
5	KAHUNA (#212)	Ballarat Grammar	Hybrid 1 OPEN (2)	542	00:01:57	00:02:39	00:27:14	5.81	♥
6	TEAM 1 (#213)	Holmesglen Institute Of Tafe	SPS (2)	523	00:01:55	00:02:45	01:05:15	8.14	♥
7	VIPERS (#230)	Chairo Christian School	Hybrid 1 OPEN (3)	522	00:02:06	00:02:45	00:11:05	6.72	♥
8	THING 2 (#204)	Damascus College	SPS (3)	517	00:01:55	00:02:46	01:38:00	12.94	♥
9	TEAM 1 (#227)	Trinity Grammar School	Hybrid 1 OPEN (4)	509	00:01:44	00:02:47	01:41:27	14.61	♥
10	THE KING (#216)	Ballarat Christian College	Hybrid 1 OPEN (5)	506	00:02:15	00:02:50	00:16:59	8.10	♥
11	HOLY CROSS 1 (#208)	Holy Cross College Ryde	Hybrid 1 OPEN (6)	487	00:02:21	00:02:57	00:14:18	10.29	♥
12	WIKI (#226)	Warracknabeal Secondary College	Hybrid 1 B/C (3)	470	00:02:11	00:03:03	00:10:15	10.53	♥

New Column

Detection

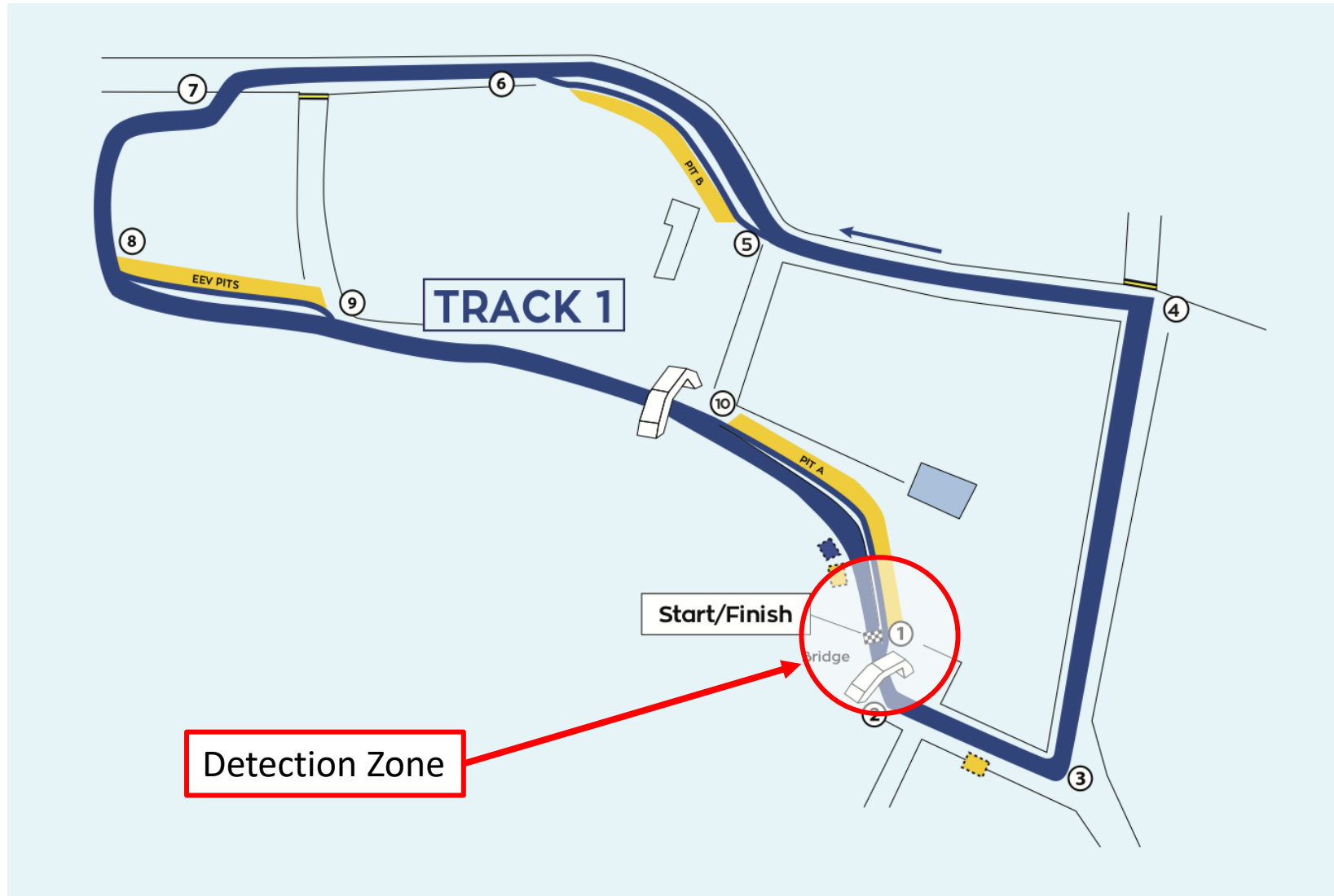

Timing System Integration

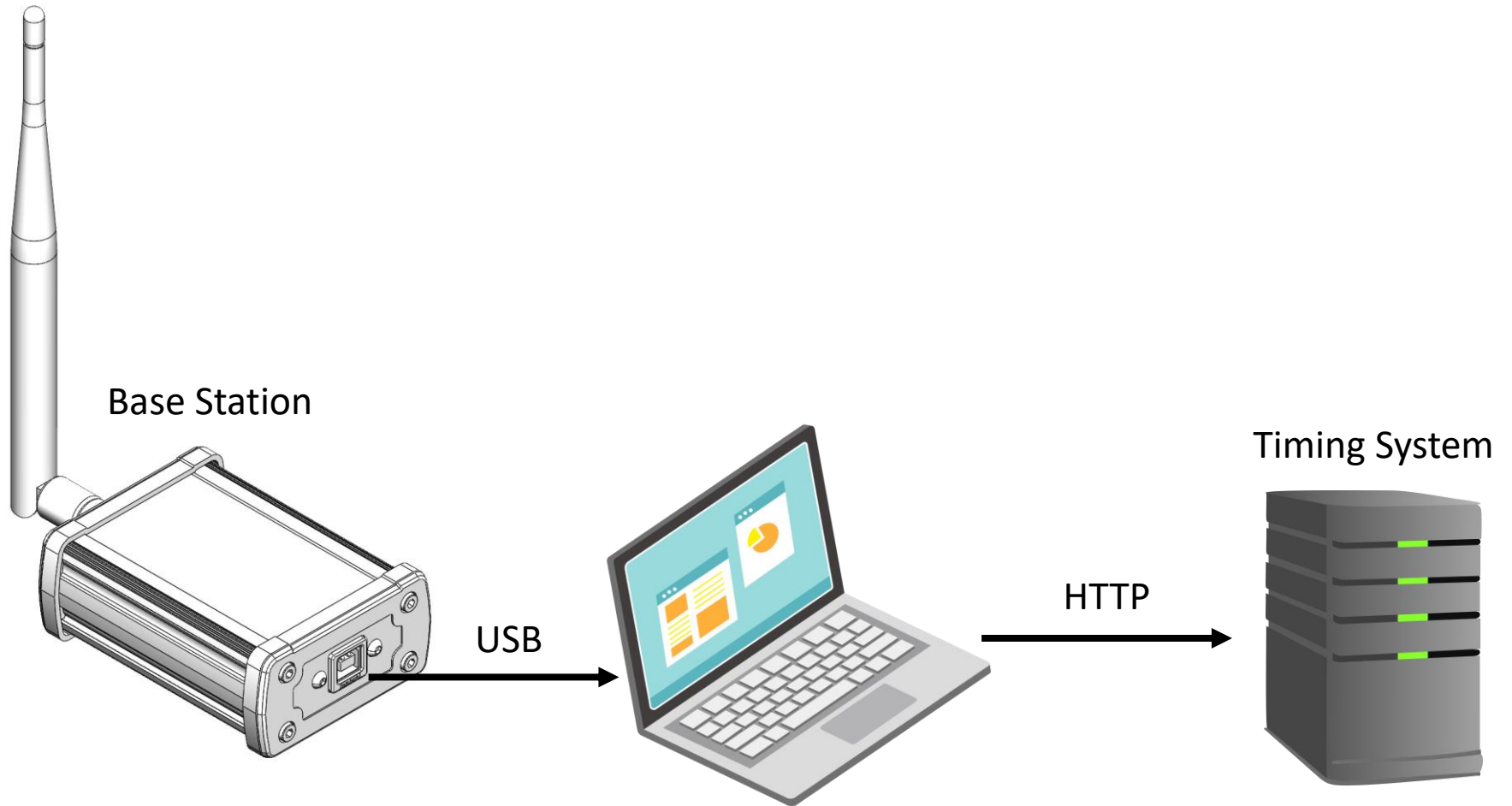

Energy Meter Specifications

- 18 to 60V Input
- $\pm 20A$
- Calibrated Accuracy $\pm 0.3\%$

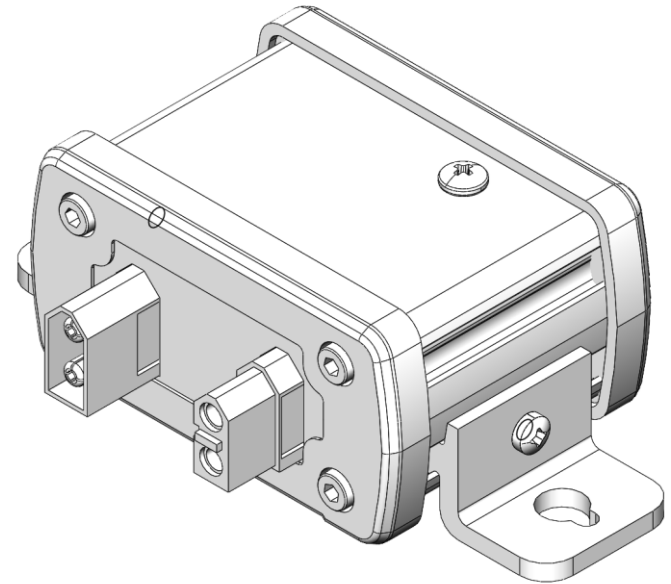

Technical Drawings

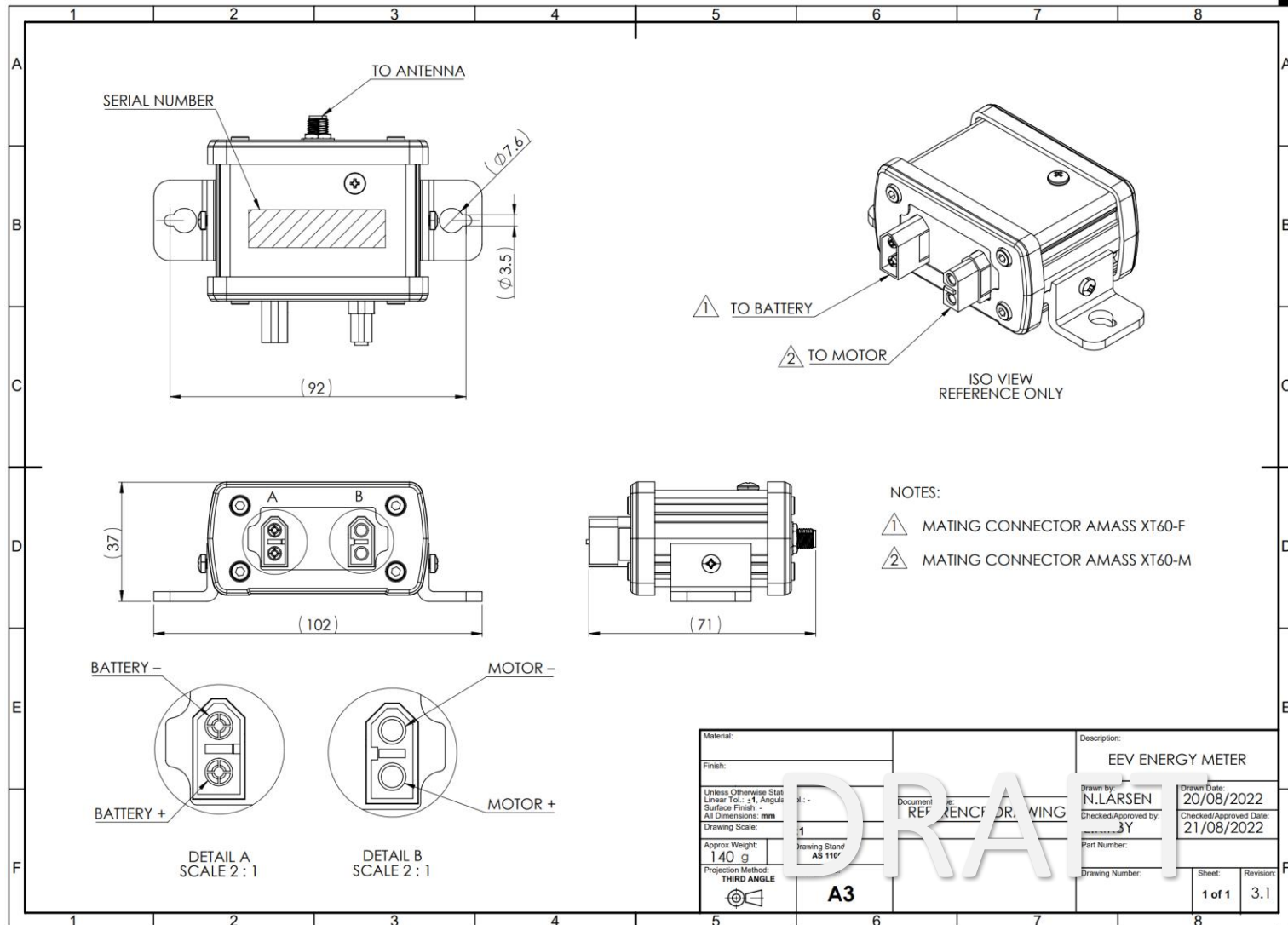

Technical Drawings

