

2019 SCHOOL'S HANDBOOK
PART B: HPV & EEV

ENERGY BREAKTHROUGH

20-24 NOVEMBER 2019 | MARYBOROUGH, VICTORIA

POWERED BY IMAGINATION

THE PREMIER SCIENCE, TECHNOLOGY, ENGINEERING AND MATHS, ACTIVE LEARNING PROGRAM

A PARTNERSHIP BETWEEN



eb.org.au

1. OVERVIEW



Ages: Open to Primary and Secondary students.

Class: A, B1, B2, C, Open, All-Female

Challenge: To work as a team of students to design, build and compete using a vehicle powered solely by human power.

2. ENTRIES

2.1 Classes

[The classification for schools entering the A1 and A2 classes will include the TOTAL school enrolment, not the Primary component of a school. This classification will be made by the organisers using information published on each school's website and the MySchools website.](#)

CLASS	YEAR LEVEL	TEAM SIZE	GENDER REQUIREMENTS	SCHOOL SIZE
A	Years 1 - 6	Min 4 - Max 10	At least 50% female.	N/a
A1	Years 1 - 6	Min 6 - Max 10	At least 50% female.	Schools with an enrolment of 200 or less
A2	Years 1 - 6	Min 6 - Max 10	At least 50% female.	Schools with an enrolment of <u>more</u> than 200.
B	Years 7 - 10	Min 6 - Max 8	At least 50% female.	N/a
B1	Years 7-8	Min 6 - Max 8	At least 50% female.	N/a
B2	Years 7-10	Min 6 - Max 8	At least 50% female.	N/a
C	Years 11-12	Min 6 - Max 8	At least 50% female.	N/a
All Female	Years 7-12	Min 6 - Max 8	Female only	N/a
Open	Up to Year 12	Min 6 - Max 8	No gender requirements.	N/a

2.2 Categories, Classes and Quotas

CATEGORY	CLASS	QUOTA
HPV Primary	HPV A1	90
	HPV A2	
HPV Secondary	HPV All Female B/C	10
	HPV B1	65
	HPV B2	
	HPV C	
HPV Open	22	

2.3 Team composition

- All entries are to be team entries and must consist of current school students (Young people enrolled in a school or young people enrolled in a secondary school certificate/program and under 20 years of age as at 31 December).
- Team members do not have to all come from the same school. They could be part of a scout, church, or other community group, however they must all be current school students and be covered by the group's insurance. Where non-school teams have riders from other schools participating in Energy Breakthrough, they must have written approval from the Principal of the school.
- Teams in the Secondary Human Powered Vehicle, Energy Efficient Vehicle and Try-athlon B/C categories will consist of:
 - a minimum of six (6) and a maximum of eight (8) riders.
 - of whom at least half must be female.
 - except in Open classes where there are no gender requirements.
- Teams in the Human Powered Vehicle A and Try-athlon A categories will consist of:
 - a minimum of six (6) and a maximum of ten (10) riders.
 - of whom at least half must be female.

2.4 Category caps, changes and waitlists:

- A maximum of three entries per school will be accepted in any category, except Innovations in Technology, which has no limit. Multi-campus schools may apply to organisers for special consideration on this quota.
- Additional entries from a school will be placed on a waiting list and will be notified if accepted into the event.
- Teams registered in the HPV B or C classes who request a transfer to the HPV Open class will incur a 50 lap penalty in the trial.
 - Teams registered in the Try-athlon A or B/C class who request a transfer to the Try-athlon Open class will incur a 15 lap penalty in the endurance trial.
 - Only one entry per school will be accepted in the HPV Open and Try-athlon Open classes.
 - Schools that have an existing entry in the HPV Open or Try-athlon Open classes will not be able to enter additional teams into this class.
 - Schools who won their class overall in the event previous, will be entitled to a guaranteed place for the following year. Team Managers will receive an email to advise of the process. If the team accepts the entry an invoice will be issued. If the

[overall winner for 2018 of a class does not want their automatic entry, this WILL NOT pass onto the second placed team.](#)

- Correspondence regarding the status of entries on a waiting list will be made directly to a Team Manager only.

3. ASSESSMENT

3.1 Overview

The Energy Breakthrough is unique in that all teams must compete across three areas of assessment: Design and Construction, Display and Presentation and Trials.

All sections must be attempted and points are awarded in the following sections:

SECTION	HPV
Design & Construction and Scrutineering	25
Display and Presentation	25
Endurance trial	50
Total	100

It is the responsibility of each team to ensure they complete all sections. The schedules for each of these sections are outlined in this Handbook and further details are provided in an Information Kit distributed in November.

3.2 Scrutineering

All Pushcarts, Human Powered and Energy Efficient Vehicles must go through scrutineering which entails a safety inspection to ensure the vehicles are safe and meet all the design specifications outlined in the relevant Part B of this Handbook. These checks ensure that the vehicle is safe for the occupant, other teams and spectators.

Scrutineering is led by Scrutineers, with support from experienced volunteers.

Where entries do not comply with specifications, or are considered unsafe, scrutineers will provide assistance and/or direction with work required in order to comply.

Schedules and locations for teams to complete scrutineering and other judging assessments are provided in the Information Kit distributed to schools in early November.

Organisers will assume that teams will have arrived in Maryborough and be available from 12 noon on the day of the assessment. Late arrivals will be accepted only by negotiation.

3.3 VicRoads Participant Licence

All team members are required to present their Licence to the VicRoads station at the start of Scrutineering & Design and Construction process at Maryborough.

If no licence is presented, any number of riders in your team will be required to demonstrate competence in vehicle control by undergoing a tough test. Safety is the number one priority at the Energy Breakthrough.

By signing the Licence, the Team Manager and Principal both certify that the student has completed the necessary track safety, vehicle maneuverability training and has read and is familiar with the Trial regulations.

Visit the [Downloads section of the website to download the Licence >](#)

3.4 Design and Construction



3.4.1 Purpose

Following scrutineering, teams will be required to demonstrate to judges that all members have developed a thorough understanding of the Design and Construction aspects of their entry.

The focus of the Design and Construction is to assess the team's understanding of the vehicle and the concepts involved in its design and construction. To this end, teams who have simply purchased a recumbent bicycle (complete or in kit form) and carried out basic modifications, will not score as well as teams who have built a vehicle from scratch. Consideration will be given to teams who have 'Inherited' a vehicle from previous teams but who have improved the design and/or construction in some way.

3.4.2 Criteria

As part of the Design and Construction assessment, teams will be required to:

- discuss and explain design and construction processes.
- show all rider safety equipment, including each person's gloves, helmets and glasses.
- show copies of relevant design drawings.

The focus for Design and Construction assessment will be:

- **Effort and input** – this is based on issues such as whether the vehicle bought, made from new, modified from the previous year and to what extent the students were involved in the various aspects of design and construction. Teams can show design drawings and models to demonstrate work undertaken by students.
- **Innovation and Quality** – how effective/clever the design concepts are; the materials used; construction methods and types of gears, brakes and steering.
- **Understanding** –the students' understanding of the vehicle design and key design concepts incorporated, the materials, components, running set-up.
- **Safety: Design and Understanding** – the use of restraints, roll bars, rider protection and visibility.
- **Practicality, Stability & On-road Performance** – vehicle reliability, handling, lighting.
- **Driver Training and Skills Development** – presentation of licences for each team member, skills covered in driver training including driving at night, in the wet, etc.
- **Understanding of Environmental Issues** –the relationship between transport and issues including greenhouse, air pollution and the importance of renewable energy,etc.

- **Vehicle Weight** – Weight is an important factor in efficiency and HPV's and EEV's will be weighed and scored based on their weight compared to other teams and the rules.

3.5 Display and Presentation



3.5.1 Purpose

The purpose of the Display and Presentation is for team members to demonstrate their knowledge and understanding of their entry.

Judges consider the different approaches taken in the presentations, such as some students reading from notes versus student presentations with limited reference to prepared notes. Schools are encouraged to be innovative in their presentations. However, care needs to be taken to ensure that 'distractions' do not overtake the real purpose, that is, '*students demonstrating their understandings*'.

3.5.2 Format

Each team will be required to present for a maximum of 20 minutes to a panel of judges. This will be followed by up to 10 minutes of questions from the judges.

This oral report will relate to the development of the team entry, including ideas that did not work and why.

The judging panel consists of three members: a community representative, a young person with an interest in education and/ or technology and an education/teacher representative. Judges will ask questions of team members following their presentation.

All registered team members are required to participate equally in the presentation. Teams may choose to include up to two (2) additional students (i.e. support crew) to join their registered team members in their presentations. However, the presentation roles must still be shared equally by all participating team members.

The display may include photos, videos, models, prototypes etc to explain the involvement of students, school, community and/or industry in the program and the development of their entry. To reduce interference from nearby panels, no public address or small music (CD) systems will be allowed without prior approval of the Display & Presentation Coordinator.

The presentation should be designed in a way that ensures information is well presented by students and enables the students to demonstrate their knowledge, understanding and involvement in all aspects of the entry.

3.5.3 Schedule

A specific time for each team to complete their Display & Presentation will be included in the Information Kit sent to schools in November. Each team is allocated time to set up their display prior to their time.

Event schedules will require teams to have arrived and be available from 12 noon on the day of the assessment. Late arrivals will be accepted only by negotiation.



3.5.4 Criteria

The assessment covers both oral and visual presentation.

Judges are asked to look for evidence of:

- Student involvement.
- Levels of participation.
- Team work and enthusiasm.
- Individual contributions.
- Understanding of the project.

It is understood that the levels of student involvement in the technical and practical activities related to the design and building of an entry will vary with age.

The oral presentation will be assessed according to:

Presentation Style:

The introduction and outline of the presentation; awareness of the audience; style of presentation (reading from notes or reciting); clarity of language; use of materials, diagrams and models covered.

Team Work:

The effectiveness of leader's role; sharing of knowledge and responsibility in the team; acknowledgment of individual team members' role; team attitude and enthusiasm and the extent to which the presentation reflects the students' own work.

Knowledge and Understanding:

Knowledge of the aims and values of the Energy Breakthrough; highlights of the school and community participation; team planning; preparation and training and technical aspects of the development of the vehicle.

Development of a Story:

About the entry, including the challenges; the preparations; the school and community's involvement and the students' achievements.

The visual display will be judged according to:

Layout and Organisation:

The range of visual media and written text depicting vehicle development; the arrangement of items; the variety of information presented and the acknowledgment of sponsorship/financial support received.

Quality of Display:

The effective use of diagrams, models, photos, text, drawings, etc. to convey message.

3.6 The Trials

In this section, the operation of each entry will be tested.

- **Secondary Human Powered and Energy Efficient Vehicles** will participate in a practice session and a 24-hour trials on a street circuit in Maryborough. The track is titled the RACV Track.
- **Primary HPV** teams will participate in a practice session and 14-hour trial on a street circuit in Maryborough.

3.6.1 The Circuits

There are two tracks in Princes Park, Maryborough surrounding the beautiful Lake Victoria. On both tracks there are some unlit sections at night, and the sealed surfaces are not “billiard table smooth”.

The **RACV Track**, shown below, is a challenging 1.76 km street circuit that reflects real-world conditions.

This track will be used for the Secondary HPV, Energy Efficient Vehicle and Pushcart sprint trials.



The **VicRoads Track**, shown below, is a challenging 1.11 km street circuit that reflects real-world conditions.

This track will be used for the Primary HPV and the Pushcart Endurance trials.

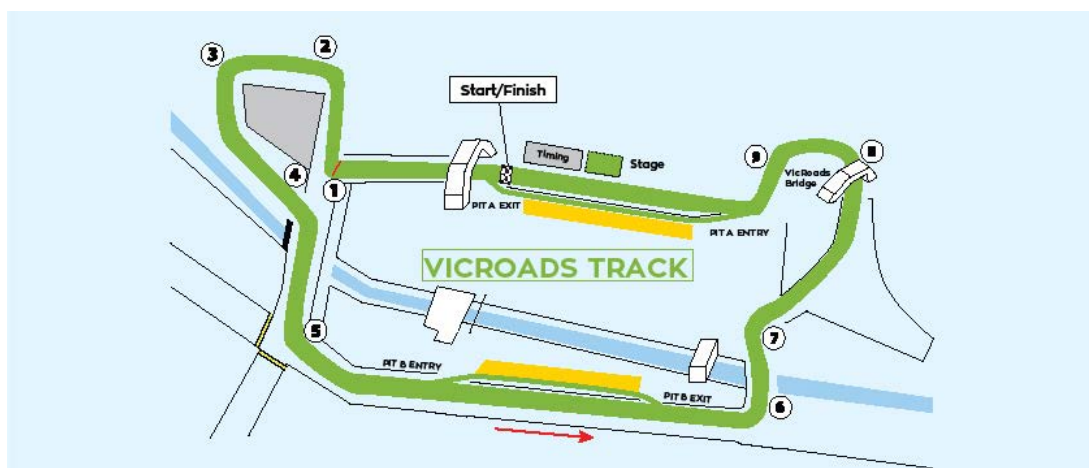

4. RIDER TRAINING

There are three key elements to Energy Breakthrough preparation:

- **Technology and design of the vehicle,**
- **Fitness and endurance, and**
- **Vehicle handling skills.**

Participants plan and prepare the first two well.

Long hours are dedicated to Design and Construction, diet and physical training plans sometimes rival Olympic efforts. However, time in the vehicle in a range of scenarios is the key to safe vehicle handling.

Manoeuvrability is an extremely important safety issue. Teams will be riding for 24 hours, so well-planned training programs may prevent accidents when riders are tired.

Riders need to have some experience and training in the demands of the track. It is essential that students are well prepared for the varied conditions and challenges at the event through pre-event track conditions simulation and manoeuvrability practice.

What should our training program include?

We recommend that all team members undertake at least 3 hours practice in the competition vehicle.

Practice in many and varied conditions, here are a few areas you should cover:

- **Safety experience**
- **Skid mitigation:** sprinkle sand or gravel on the track turn the wheels into a skid
- **Wet conditions training:** hose your training track down to simulate rain
- **Night riding practice:** come back after dinner
- **Cornering:** chalk some tight corners onto the asphalt
- **Cutting in and out of 'the pack':** use witches hats
- **Passing slower vehicles:** use a bicycle as the other vehicle
- **Defensive driving techniques:** be ready for the unexpected.
- **Pit Procedure:** practice smooth rider changeovers, including fastening seatbelts, adjusting seats and adding drink bottles.
- **Traffic lights and flag signals:** test each other to know what each light and flag colour means.

The traffic lights/flag signals are the main way for Marshals and Traffic Officials to communicate with riders during the trial. During Design and Construction assessment members will be questioned about their knowledge of Traffic Lights/Flag Signals and track Conduct.

Here are some extra tips to help you prepare:

Driver position

Each team driver should be able to reach the pedals and be comfortable over their full range of movement, without stretching the leg straight.

Make sure the back is fully supported so that maximum effort can be applied to the pedals without needing extra support gained by pulling back on the steering wheel.

Both mirrors should be adjusted so that a vehicle following close behind – either side – can be clearly seen without undue head movement.

Seat belts must be worn low over the pelvic bone (not high over the waist) and across the chest. The belt should be comfortable, firm and not prone to slipping off the shoulder.

The seat position must ensure that the rider does not slide forward and under the seat belt.

Corners

A blue line is marked on the track. Vehicles are required to stay on the inside of the track (that is to the left of the blue line) at all times unless overtaking.

When entering a bend, look to where you want the vehicle to go – this will help to pull you through in a smooth curve.

Mirrors

You must always be using your mirrors to know what is behind you, or if you are going to be overtaken, and to be aware of other vehicles around you.

Finally, if you are planning to move from one side of the track to the other, give a quick glance over your shoulder to avoid moving into the path of another vehicle.

Steering the vehicle

Use a light grip on the steering wheel or levers; push the pedals from the hips, back and shoulders, with relaxed arms. This will allow you to steer smoothly and keep a straight line.

VicRoads Log Book

With the help of VicRoads, an optional Log Book has been prepared for students to record their training and preparation.

[Find the VicRoads Log Book in School Zone](#)

VicRoads Participant Licence

All team members are required to present their Licence to the VicRoads station at the start of Scrutineering & Design and Construction process at Maryborough.

[Find the VicRoads Log Book in School Zone](#)

HUMAN POWERED VEHICLES (HPVS) - PRIMARY*

All Track activities are on the VicRoads Track.

WEDNESDAY 20 NOVEMBER

1.00 pm – 5.00pm Registration open

Location: Administration Centre

3.30pm – 6.00pm Design and Construction and Scrutineering

Location: Display & Presentation marquees

THURSDAY 21 NOVEMBER

9.00 am Registration opens

Location: Administration Centre

9.00 am – 5.00pm Display and Presentations

Location: Display & Presentation marquees

8.30 am – 5.30pm Design and Construction and Scrutineering

Location: Display & Presentation marquees

6.00pm Rider Briefing

Location: In front of VicRoads Track Stage

6.30 pm – 8.30 pm Practice Session

VicRoads Track

FRIDAY 22 NOVEMBER

11.00 am Team Managers' Briefing

Location: Rear of VicRoads Track Stage

11.30 am Assembly of Starting Grid

Location: Front Straight, VicRoads Track

12 noon HPV A Trial Start

Location: VicRoads Track

8.00 pm Compulsory HPV A Break

SATURDAY 23 NOVEMBER

6.00 am HPV A Restart

Location: Pit Lane, VicRoads Track

12 noon HPV A Trial Finish

3.30 pm Presentation Ceremony (Primary)

Location: Stage in Energy Expo area

SUNDAY 24 NOVEMBER

All teams should have arrived and registered by 12noon on Thursday. Display & Presentation and Design & Construction schedules will be prepared with this in mind.

No activities

*** PLEASE NOTE THAT THIS TIMETABLE IS SUBJECT TO AMENDMENTS**

HUMAN POWERED VEHICLES (HPVS) - SECONDARY*

All Track activities on Track 1

WEDNESDAY 20 NOVEMBER

4.00 pm – 5.00pm **Registration open**
Location: Administration Centre

All teams should have arrived and registered by 12noon on Friday. Display & Presentation and Design & Construction schedules will be prepared with this in mind.

THURSDAY 21 NOVEMBER

All Day Teams arrive and set up camp

11.00 am **Registration opens**
Location: Administration Centre

FRIDAY 22 NOVEMBER

All Day Teams arrive, register, set up camp, set up displays etc.

8.00 am – 6.00 pm **Scrutineering, Design and Construction**
Location: Display & Presentation Marquees

9.00 am – 6.00 pm **Display and Presentation**
Location: Display & Presentation marquees

5.30 pm **Spirit of Competition – Team Captain’s Meeting**
Location: Hospitality Marquee, Track 1 front straight.

6.30 pm **Team Managers’ Meeting**
Location: Hospitality Marquee, Track 1 front straight

7.15 pm **Assembly for Night Practice**
Location: Pit Lane, Track 1

7.30 pm – 9.30 pm **Night Practice**
Location: Track 1

SATURDAY 23 NOVEMBER

12:00 pm **Assembly of Starting Grid**
Location: Back straight, Track 1

1.00 pm **Start of 24-hour Trial**
Location: Track 1

SUNDAY 24 NOVEMBER

1.00 pm **Finish of Trial**
Location: Track 1

1.45 pm **Presentation of Trophies (Secondary)**
Location: Stage in near Display & Presentation marquees

Afternoon Pack up and depart.

Note: Teams may stay overnight on the Sunday after the event to ensure that the team travels home safely.

*** PLEASE NOTE THAT THIS TIMETABLE IS SUBJECT TO AMENDMENTS.**

Energy Efficient Vehicles (EEVs)*

WEDNESDAY 20 NOVEMBER

4.00 pm – 5.00pm **Registration open**
Location: Administration Centre

All teams should have arrived and registered by 12noon on Friday. Display & Presentation and Design & Construction schedules will be prepared with this in mind.

THURSDAY 21 NOVEMBER

All Day **Teams arrive and set up camp**

11.00 am **Registration opens**
Location: Administration Centre

FRIDAY 22 NOVEMBER

All Day **Teams arrive, register, set up camp, set up displays etc.**

8.00 am – 6.00 pm **Scrutineering, Design and Construction**
Location: Display & Presentation Marquees

9.00 am – 6.00 pm **Display and Presentation**
Location: Display & Presentation marquees

5.30 pm **Spirit of Competition – Team Captain’s Meeting**
Location: Hospitality Marquee, Track 1 front straight.

6.30 pm **Team Managers’ Meeting**
Location: Hospitality Marquee, Track 1 front straight.

7.15 pm **Assembly for Night Practice**
Location: Pit Lane, Track 1

7.30 pm – 9.30 pm **Night Practice**
Location: Track 1

SATURDAY 23 NOVEMBER

10.00 am **Vehicle Fuel-Up**
Location: To be advised.

12.00 pm **Assembly of Starting Grid**
Location: Back straight, Track 1

1.00 pm **Start of 24-hour Trial**
Location: Track 1

SUNDAY 24 NOVEMBER

1.00 pm **Finish of Trial**
Location: Track 1

1.45 pm **Presentation of Trophies (Secondary)**
Location: Stage in near Display & Presentation marquees

Afternoon **Pack up and depart.**

Note: Teams may stay overnight on the Sunday after the event to ensure that the team travels home safely.

VEHICLE SPECIFICATIONS

HUMAN POWERED VEHICLE AND ENERGY EFFICIENT VEHICLE SPECIFICATIONS

Version 2019.01

Introduction

- These vehicle specifications cover the HPV Primary, HPV Secondary, EEV and TRYathlon categories.
- EEV vehicles must also comply with EEV Specifications Supplement.
- [Any significant specification changes from previous editions been highlighted and underlined in blue.](#)
- **Key specifications that the Scrutineers wish to bring to the attention of Team Manager's have been highlighted in bold.**
- If changes are made to these specifications prior to the event, Team Managers will be notified via email and a new edition will be published on the website.
- The Energy Breakthrough (EB) Scrutineers have the final authority to decide if any vehicle or team participates in the event, based on safety and their interpretation of the following rules.
- All enquiries regarding HPV and / or EEV Specifications should be emailed to Lead Scrutineers Michael McTigue and Tim White via technical@eb.org.au

SCOPE & CONFIGURATION

Intent

The Energy Breakthrough is intended as an experiment in personal mobility. The objective is to build an efficient and stable machine powered either entirely by human effort (Human Powered Vehicle) or a combination of power sources (Energy Efficient Vehicle).

To support students learning, entrants are encouraged to:

- Participate in the design and construction of the vehicle whether it is from a clean sheet or the modification of an existing vehicle.
- Understand the fundamental design and construction elements of the vehicle.
- Liaise with local industry or community groups to design and build a machine.

Seating Capacity, Wheels

The vehicle shall carry a rider alone and shall have three or more load bearing wheels arranged in a stable configuration.

Riding Position

- The riding position shall not compromise machine control or safety, nor shall the riding position place the rider in a potentially hazardous position in the event of a collision.

- A prone riding position, or horizontal riding position is not permitted.
- It is not advisable for the bottom bracket to be higher than the rider's heart.

Power Source

HPV

Motive power shall be entirely supplied by the rider.

EEV

See EEV Specifications Supplement.

Potential Maximum Speed

The maximum speed of vehicles shall be 60 km/h. The Trial is a test of endurance and efficiency and therefore vehicles should not be designed with achieving extremely high speeds.

DESIGN AND MATERIALS

Inherent Safety

The design shall provide protection for the rider in the event of a collision or rollover.

The design must be free of protrusions or other features capable of causing interference or injury to fellow competitors or spectators.

Vehicle control and stability shall not be jeopardised by inappropriate design and construction methods.

[The onsite repairing, securing or joining of steering, brake or any other safety related components with glue or epoxy resins during the event, must be carried out in the specified repair area, with an event scrutineer present.](#)

The cockpit must be free of hazards that could injure the rider or pit crew. For example:

- Zip tie ends need to be cut flush, filed round, taped over or rotated away.
- Brake and gear cable ends should be covered with cable caps.
- No bare edge, rigid material shall be within 250 mm of the rider's face.

Exclusions

Choice of design and construction materials is free, except that:

- Designers and constructors are permitted to freely use any bicycle component except for complete frame sections.
 - The use of Go-Kart frames or motorbike frames is not permitted.
 - Maximum overall tyre width is 70 mm.
 - Rope, cable, tilt, lean steering systems and flexible steering columns are prohibited.

VEHICLE DIMENSIONS & TURNING CIRCLE

Length

2700 mm maximum

Width

1100 mm maximum

Height

1200 mm maximum

Wheelbase

1000 mm minimum wheelbase between the most forward and most rearward axles.

Track

600 mm minimum (width between centres of outermost tyre ground contact points)

[Teams wishing to construct a four wheeled vehicle are required to meet the following track dimensions:](#)

- [One of the vehicles track widths must be a minimum of 500mm.](#)
- [The sum of both axle's tracks is to be 900mm minimum.](#)

Turning circle

[It is recommended that HPV Primary, HPV Secondary and EEV vehicles can meet a 12 metre turning circle. This will be demonstrated during scrutineering with a slalom test.](#)

It is recommended that TRYathlon vehicles can meet an 8 metre turning circle. This is due to the two hairpins in Tryathlon Obstacle course. [This will be demonstrated during scrutineering with a slalom test.](#)

VEHICLE WEIGHT

HPV

50kg maximum

EEV

Single Power Source - 60kg maximum

Hybrid 1 - 60kg maximum

Hybrid 2 - 80kg maximum

The EEV specified maximum weight includes batteries.

Note:

EEV teams are encouraged to make their vehicles as lightweight as possible without compromising safety.

BODYWORK

Bodywork configurations

There are three bodywork configurations, which impact the structure of the vehicle:

1. Open bodywork (or 'head out') vehicles requiring full roll bar protection.
2. Aerodynamically enclosed vehicles with a soft shell or corflute panels requiring full roll bar protection.
3. Fully enclosed hard-shell bodywork vehicles built from a stiff composite material. (ie. carbon fibre / kevlar / fiberglass)

Note:

The test for whether a vehicle will be accepted as a fully enclosed hard-shell is if the roof is able to support the weight equivalent to a rider between the rider's head and their knees. If the roof is unable to support this weight it will be deemed 'aerodynamically enclosed' and must meet all roll bar requirements.

Multiple configurations and removal

- If teams prepare multiple bodywork configurations for use, then all configurations must comply with all specifications and must be presented for approval during Scrutineering.
- Bodywork must not be removed Practice Sessions and the Trial; between TRYathlon events; or during the Trial if doing so compromises occupant safety. (i.e. Removal of the roof in hard shell vehicles.)

Access for Enclosed Bodywork Vehicles

- The rider shall be able to open and/or remove bodywork and exit the vehicle without external assistance.
- Bodywork shall be capable of being easily opened and or removed from outside the vehicle independently of the rider by someone who is unfamiliar with the vehicle. In an emergency marshals must be able to open the vehicle without explanation.
- The location of closure devices for opening body sections must be marked outside with a triangle of contrasting colour to the body and side length of at least 100 mm making it clear for anyone unfamiliar with the vehicle. [These stickers will be provided in the sticker kit supplied at Check-In at the event.](#)
- If a hole has been cut in a window to enable access to an elastic strap then the hole must be at least 100 mm wide to allow for an adult hand to easily reach into the vehicle.

Bodywork Clearance

- **There must be a forward clearance of at least 300 mm between the rider's face and any bodywork.**

Vision

- Rider vision must not be impaired by excessively enclosed and restricting bodywork

- Side windows must be incorporated in the vehicle body design and must extend from the shortest rider's shoulder line to above and behind the tallest rider's eye line. Riders must have a clear view over their shoulders to see surrounding vehicles.
- Windows must not be tinted or covered with any stickers, regardless of if they are intended to be see-through.
- Windows must allow marshals to monitor designated riders and correct riding apparel during the Practice Sessions and Trial.

Vision Tests

The shortest rider and the tallest rider seated in their normal riding position will be required to have sufficient vision to comply with the following vision tests during scrutineering:

- Sight an object on the road 5 metres in front of the vehicle.

Diagram 5.5.1A Forward Vision Test

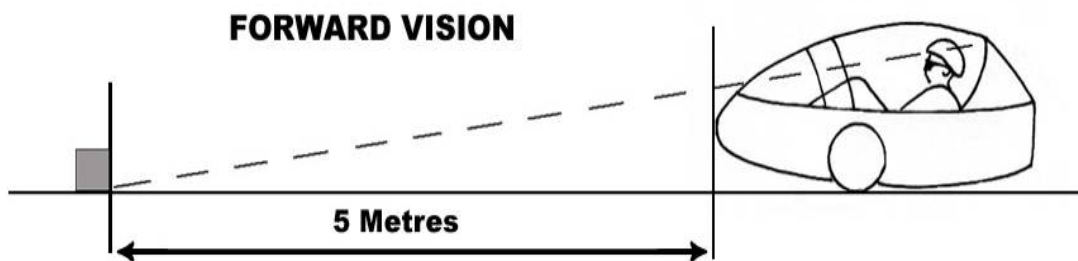
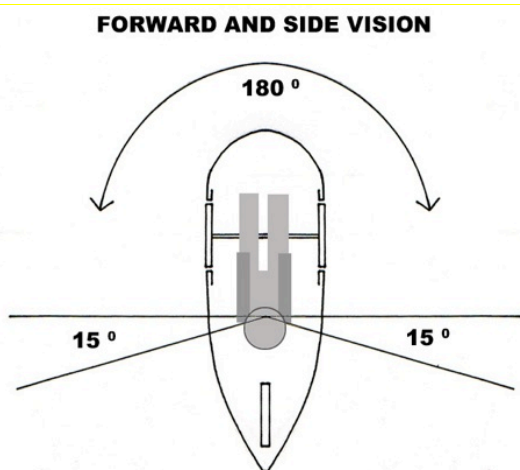

Diagram 5.5.1B Forward and Side Vision Test



- Sight 180 degrees ahead of the rider.
- Be able to turn their head sufficiently to see 15 degrees behind the rider on each side of the vehicle. The intent of this clause is that a rider is able to turn their head to visually check for other vehicles before changing their position on the road.
- Riders must be able to demonstrate that the mirrors can provide adequate rear vision.

Ventilation

- Rider and vehicle safety must not be impaired by restricted ventilation.
- [Airflow for rider ventilation, provision to mitigate rain and window fogging should be considered in vehicle design.](#)

RIDER PROTECTION

Protection Bars for Open and Aerodynamically Enclosed vehicles

Open and Aerodynamically Enclosed vehicles must have four sets of protection bars:

1. “Head bar” (main bar) including brace,
2. “Forward leg bar” including brace,
3. “Side intrusion bars”, and
4. “Overhead protection bars”.

Construction

- All protection bars, including bracing must be constructed from metal meeting the minimum outside diameter (O.D) specifications in the following table.
- All bars except the overhead protection bar must be joined either by welding or plate method (Refer 6.9: Plate Joints)
- The overhead protection bar may be hinged and locked to enable easier access for riders.

	HPV & EEV1	EEV 2 & SPS
Steel or Chromoly tubing.	12.7mm O.D	16.0mm O.D
Aluminium tubing	16.0mm O.D	19.0mm O.D

Diagram 6.2A and 6.2B: Positioning of Protection Bars

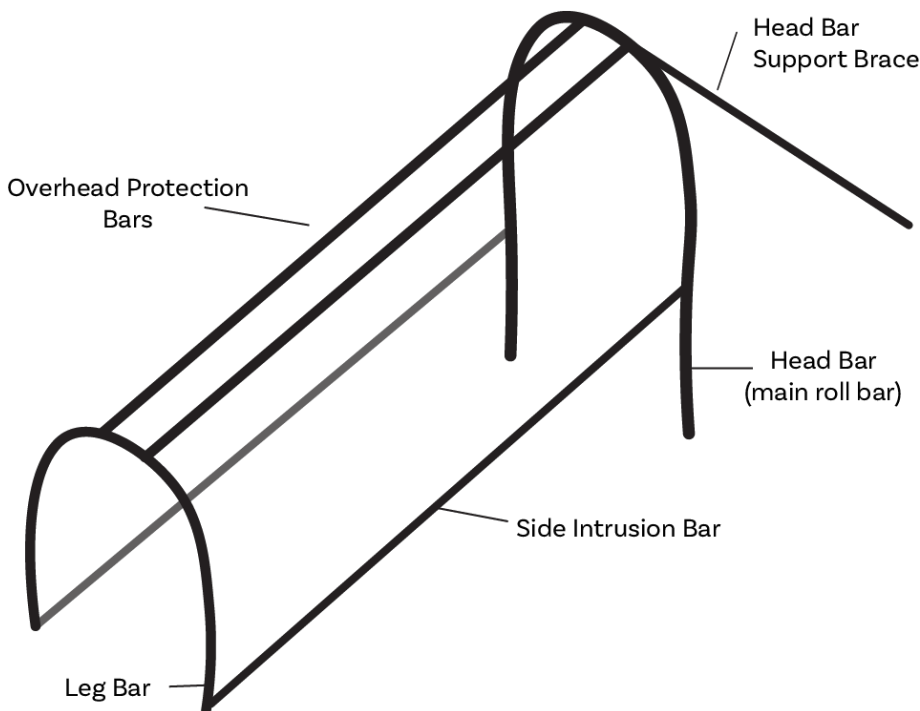

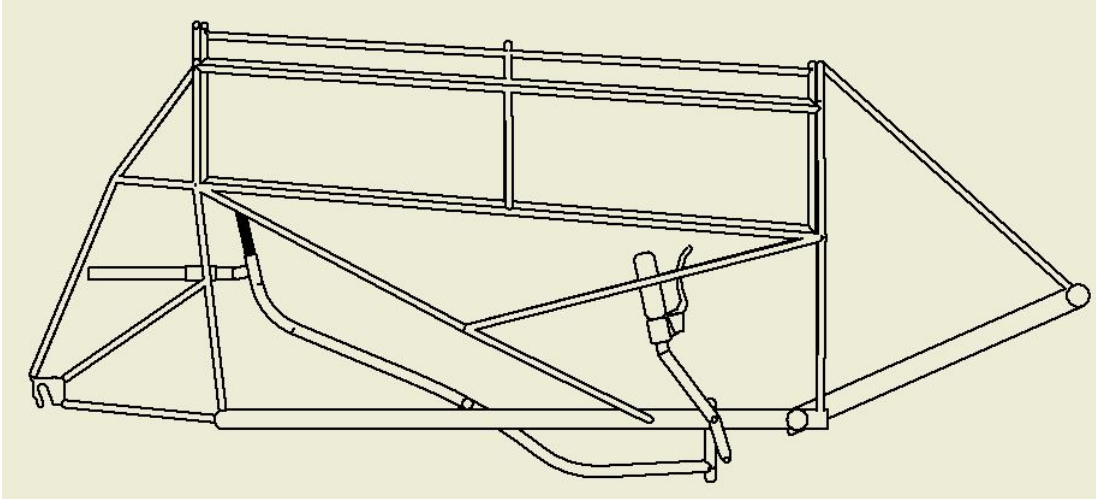

(Please note: Drawings are not to scale)

Head Bar

- The main “head bar” and brace together with the side intrusion bars must be one continuous welded frame, constructed according to Diagram 6.2A and must be solidly attached to the vehicle frame. (Refer 6.9: Plate Joints)
- The “head bar” hoop must be braced from its highest point with one bar, preferably two, to a major structural member to form a tripod.

The head bar must conform to the following dimensions:

- With the tallest of the competing riders in the normal riding position, the “head bar” must be fully visible outside the rider silhouette when viewed from the front or rear.
- [Measurement from helmet to inside of bar: 100mm minimum](#)
- Measurement from either side of helmet to inside of bar: 100mm minimum
- Clearance around rider’s body to inside of bar: 50mm minimum
- Location forward or rearward of helmet: 150mm maximum

Diagram 6.3: Head Bar clearance in open top or aerodynamically enclosed vehicles

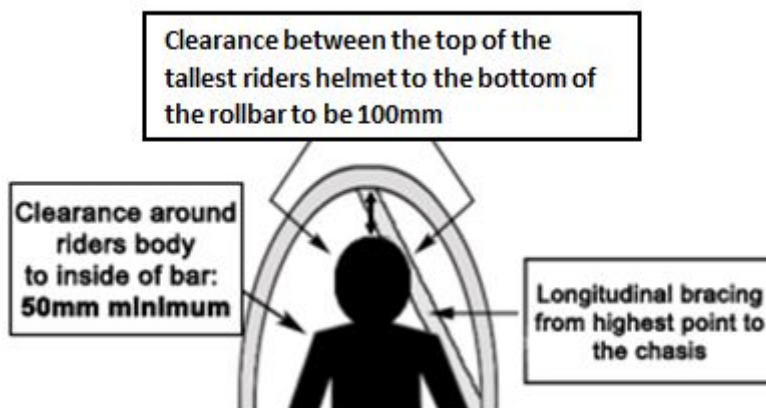

Leg Bar

- The “leg bar” must protect the rider’s legs, knees and feet from contacting the ground in a rollover or side slide situation and must be mounted across the vehicle above the riders knee area.
- The “leg bar” must be braced to prevent the bar from folding over in a rollover or sliding situation.

Side Protection

- The vehicle must have side intrusion bars typically in line with the rider’s that are an integral part of the continuous “head bar”.
- In addition to the side intrusion bars, side protection bodywork or shielding is required to protect the area between the rider’s hip and shoulder from making contact with another vehicle and to prevent the rider’s shoulders and arms from reaching the ground in the event of a rollover.
- This side protection bodywork should be constructed from suitably strong materials that will withstand sliding contact with the road.
- No part of the rider is allowed to protrude outside the side protection during normal operation.
- [There must be a clearance between any part of the rider and the shielding.](#)

Diagram 6.5: Side Impact Protection

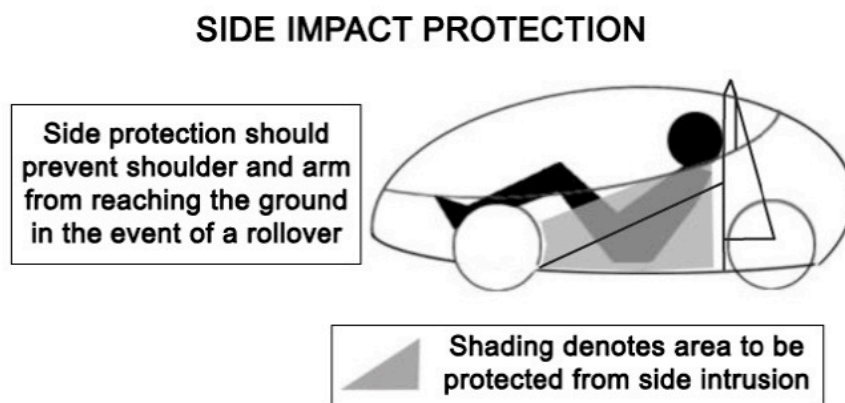

Overhead Protection

- The structure over the head of the rider must provide enough strength to prevent the rider’s head from being struck by another vehicle when on its side after a roll over.
- Open top and aerodynamically enclosed vehicles must have two longitudinal bars connecting the main head bar to the knee bar.
- Bars must be symmetrical around the vehicle centreline and there must be 100mm to 200mm of separation between the bars.
- **The overhead protection bars must have at least 50 mm clearance above any part of the rider when viewed from the side.**

- These bars may be detachable or hinged to enable easier access for riders, but must lock in place and be strong enough to ensure the structure remains attached during a rollover.

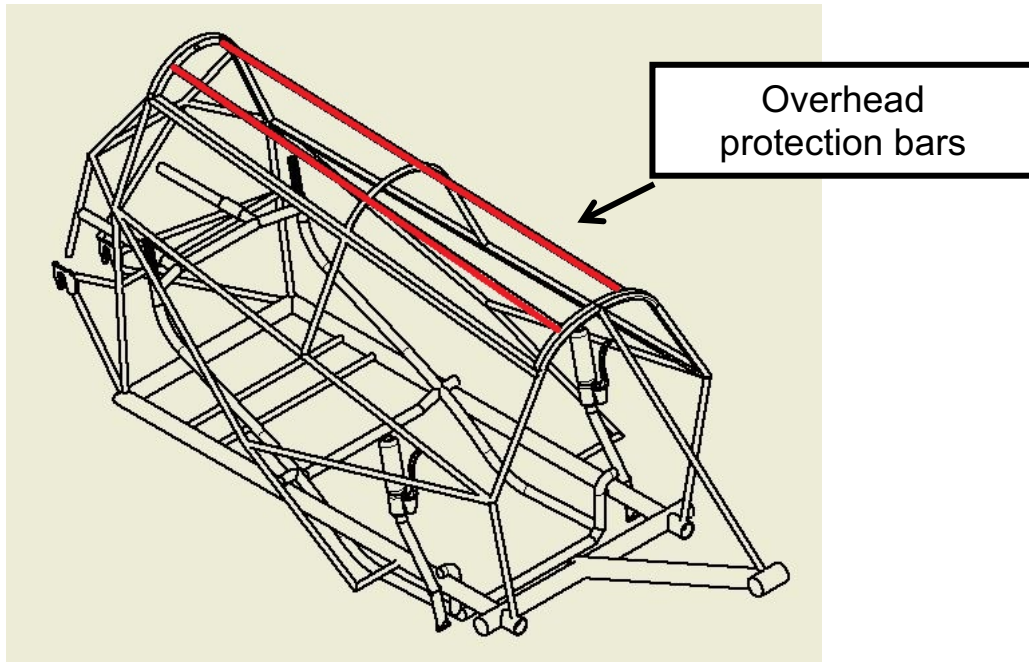

Rider protection for fully enclosed hard-shell vehicles

Fully enclosed bodies made from composites such as Carbon-Fibre, Fibreglass or Kevlar do not require metal protection bars provided they comply with the following requirements for strength and build quality tests:

- The body must have strengthened ribs moulded into the composites that are of at least equal strength to a metal roll bar. (eg: The roll bar area should not be able to flex when pressed by hand)
- All composite roll bar and side intrusion bar ribs must follow the same positioning as the metal protection bars outlined in section 6.1.
- All composite constructions must have finished edges. That is no protruding fibres or frayed edges.
- Metal roll bars can be used with composite bodies.
- Any joins must follow the plate mounting method. (Refer 6.9: Plate Joints)

Note:

- The test for whether a vehicle will be accepted as a fully enclosed hard-shell is if the roof is able to support the weight equivalent to a rider between the rider's head and their knees. If the roof is unable to support this weight it will be deemed 'aerodynamically enclosed' and must meet all roll bar requirements.
- The onus is on schools to ensure that their vehicle is compliant with the required safety standards. The Energy Breakthrough website includes some advice on composite construction.
- **All teams constructing new hard-shell composite vehicles with integral protection bars are encouraged to send photos to the technical contacts for review by the end of October.**

Rider Protection Clearances for fully enclosed hard-shell vehicles

Hard-shell vehicles are required to have a piece of Ethylene Vinyl Acetate (EVA) foam placed above the rider's head.

This foam must be:

- Of Density 105kg/cubic metre.
- Minimum 20mm thickness.
- Minimum area of 1200cm². (or dimensions of 200mm x 600mm).

Riders are required to maintain clearance between helmet and foam at all times.

Note:

it is strongly recommended that teams install additional foam protection around the rider's shoulders and arms.

Plate Joints

- Where metal protection bars are to be joined without welding or attached to a composite body, plates should be used to distribute the loads into the body.
- A matching plate should be used on either side of the composite body and spacers must be used to prevent crushing of the composite structure.
- The plates must be joined using at least two 6 mm bolts with locking nuts (eg. Nylock Nuts).

Forward Protection & Nose Cone

All vehicles must have adequate forward protection to reduce the chance of injury in the event that the vehicle collides with a person or another vehicle.

- **The front of the vehicle must have a curved nose to prevent easy penetration of another vehicle. At 100 mm from the front, the vehicle must have a cross section greater than 200 mm.**

SEAT

Positioning

- The seat must be fitted in a way that ensures that the riding position does not compromise machine controllability or safety, nor shall the riding position place the rider at risk of neck or back injury in the event of a collision.
- The seat must be shaped and positioned to prevent the rider sliding under the seat belt.
- In vehicles with moveable seats, riders must remain protected by the side intrusion bars in all seat positions.

Locking of Seat Position

- The seat must be securely mounted.
- Adjustable seats must lock securely into position for each rider and must not move forward or backward.
- Seat belts cannot be used as part of the seat lock system.

Additional Padding

- Any temporary or removable padding used for riders **MUST** be fixed into place using a positive attachment to a fixed part of the vehicle.
- This could be a strap and buckle, velcro straps, dog clips, canvas zips, etc.

Head Restraint

The vehicle must have a padded head restraint behind the rider's head that reduces the chance of over extension of the rider's head backwards.

SEAT BELT

Type

- **The vehicle must be fitted with an Approved and Certified adult four point (minimum) seat belt for all riders.**
- Seat belts must have certification label attached.
- The seat belt must be in good condition and completely standard, including buckle, stitching and mounting plates.
- Teams will be required to demonstrate adjustment of the seatbelt to suit each rider.

Suggested suppliers

- Hemco Industries - <http://www.hemco.com.au/> or Ph: 1300 065 057
- APV Safety Products: 4 point, 2 inch webbing available through most automotive parts stores.

Mounting

- **The belts cannot be mounted to the seat surface alone under any circumstances.**
- The belts can be mounted through the seat to a bracket/plate/tube that is at least the strength of the seat belt mounting plate and that the strength can be traced all the way to the structural frame of the vehicle.
- Upper belts mounted behind the rider's shoulders are required to be horizontal or no more than 40 degrees from horizontal and mounted no more than 200mm apart so as not to allow the belt webbing to fall from the shoulders when riding.

Positioning

Correct and safe positioning of the belts and catches can be found in the Australian Design Rules (ADRs) for motor vehicles.

This means seat belts must:

- Be positioned such that it does not have any contact with, or rub against, any sharp edges
- Be worn over the shoulders and down the chest, to a low lap belt across the pelvis.
- Be adjusted to be as firm as possible on each rider and fitted to ensure that the seat belt remains properly adjusted on each rider at all times.
- be adjusted with the lap belt tightened before the shoulder belts so that the lap belt remains in the correct position.

SHIELDING

Rider Protection

The rider must be shielded from any rotating mechanical part in the vehicle. This includes chains, sprockets and teeth, as well as wheels and tyres.

[Diagram 9.1A Front Chain Guard And Sprocket Guard Examples](#)

Rigid Chain Guard

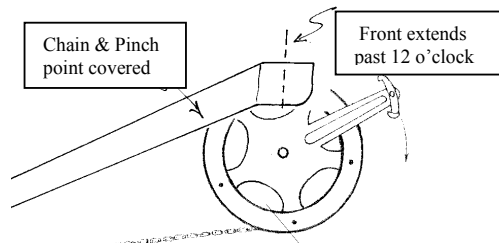

Chain Tube and Sprocket Rings

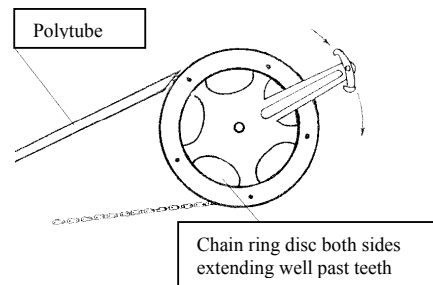

- Chains, sprockets and gears **MUST** be fully shielded to prevent accidental hazardous contact with rider or clothing.
- Chain ring teeth must be covered both sides using chain ring discs.
- A hair shield must be used to prevent long hair from falling anywhere near the rear wheel, chain or gear components.
- **All vehicles must have inner guards which completely separates the rider from the wheels. This means that the front and rear wheels and tyres **MUST** be fully shielded from the rider.**
- Wheel guards can be made using core-flute.

[Diagram 9.1B Front Wheel Shielding Example:](#)



Protection of other Vehicles

- Chains, gear wheels and sprockets shall be suitably shielded to prevent their contact with other vehicles.
- Exposed axle ends have to be recessed or flush in the hub, covered by bodywork, bar work, dome nuts or wheel covers.

Shielding from Road Surface

- Vehicles must be fitted with an under-tray or floor panel which prevents the rider's feet from contacting the ground when seated in the riding position.
- Pedal toe clips, elastic straps or pedal-to-shoe locking devices do not fulfil the requirements of this clause.

STEERING

Type

The type of steering mechanism is free, except for:

- Rope, cable, tilt, lean, and flexible steering columns are prohibited.
- **A minimum clearance of 300mm is required between the riders face and the steering controls.**
- The rider must have continuous positive control without the need for regular adjustment.
- Adjustable steering columns must be fitted with a secure/ positive locking mechanism, i.e. a bolt and locknut or over-centre locking clip.
- Adjustable steering columns cannot be fixed using Pins and R clips.
- [Rear wheel steer vehicles can be designed and constructed by teams, provided that a submission is made to the Scrutineering team and adequate prototyping is carried out prior to the event.](#)

Freedom from Binding and Fouling

Steering linkages shall operate freely from full left to full right lock without binding or fouling.

Lock Stops

- To prevent the rotating road wheels from coming into contact with any part of the vehicle or rider, there must be positive steering lock stops.
- The steering mechanism or any solid component that moves with the steering mechanism must come up against a solid bracket or non-flexible part of the body or frame on full lock in either direction and stop any further steering travel.

BRAKES

Type

- The front axle braking system shall be either drum or disc type.
- They must not act on the wheel rims.
- No brake systems should apply friction contact to the tyres.

Braking configuration

- The vehicle must have a minimum of two independently operated braking systems, both systems must be operational at all times.
- Both front wheels must have a braking capability.

Teams are free to choose from two types of braking configurations:

1. "Single Lever": Both front wheels are operated via a single lever.
In this configuration, a rear brake IS necessary.

2. “Independent”: Both front brakes are operated via an independent braking lever (ie/ Left hand lever for left hand brake).
In this configuration, a rear brake IS NOT necessary.

Note:

Team Managers are encouraged to provide additional training opportunities for riders prior to the event for vehicles with “Independent” braking systems.

Steering Control

Full steering control shall be maintained while braking systems are being operated.

LIGHTING

Headlight

- Front lighting must be at least one white light, securely mounted a maximum height of 600mm above road level, at the front of the vehicle (ie. forward of the rider’s feet).
- Lighting must be adequate to provide good visibility for the rider to see the track in the dark.
- Additional lighting to improve the rider’s vision is encouraged provided at least one light meets the designated requirement.
- Headlights are not to be flashing.

Note:

Sections of the track are in darkness at night and sufficient lighting will be required to see the road.

Tail Light

Rear Lighting must be:

- a) Fitted and turned on for the duration of all on track events.
- b) Red LED colour only
- c) Set to steady mode ONLY
- d) Mounted within 150mm of the rear-most part of the vehicle.
- e) Mounted on the vertical centre line of the vehicle.
- f) Visible through 160° rear sweep.
- g) Securely mounted between 350mm and 600mm above road level.
- h) All red lights on the vehicle must be rear facing and comply with (a – g)
- i) A minimum of three LEDs

Outline Lighting

The use of reflective material or strip lighting to indicate machine width and height (especially from the rear) is encouraged.

Mounting

All lights are required to be securely mounted for the duration of the event to maintain correct aim.

Helmet Mounted Lights

Helmet mounted lights are not to be used.

Batteries

- Wet cell batteries must be housed in a sealed box (e.g. plastic) that will prevent spillage if the battery is inverted or damaged.
- All electrical connections for lights or warning devices must be of an automotive or industrial standard with fully insulated connectors.

MIRRORS

- At least two effective rear-view mirrors of a minimum area of 18 cm² must be fitted, one on each side of the vehicle, and having similar reflection (i.e. same size image) in order to clearly identify overtaking traffic and meet the rear vision test during Scrutineering.
- Mirrors may be of the mildly convex type.
- The smallest rider must be able to reach each mirror from the normal riding position.

WARNING DEVICE

- **An electronic audible warning device shall be fitted (e.g. smoke alarm siren) and operate from the normal riding position.**
- The warning device must be directed forwards and directly contact the outside airstream.
- The device must not run continuously and operate via a momentary switch.
- The warning device should be waterproofed.

OTHER DEVICES

- Any other equipment, e.g. drink bottle, shall be securely mounted and shall not impair rider control in its mounting or use.
- The use of MP3's or similar music /entertainment devices by riders is NOT permitted.
- Small video cameras (eg. GoPro) are allowed as long as they are not attached to the rider's helmet and are positioned so that they cannot pose any safety risk.
- Cameras should not be mounted outside the silhouette of the vehicle when viewed from the front.

SPEEDOMETER

- All vehicles shall be equipped with an electronic speedometer (e.g. Garmin) to monitor speed during the event (pit area speed limit of 10 kph, track speed limit of 60kph).
- This speedometer must be mounted on the vehicle in a position where the rider can see from normal riding position.
- A wristband-based speedometer worn by the rider is not acceptable.

TRANSPONDER

- Vehicle design should allow for a lap counting transponder to be mounted:
 - inside the vehicle
 - securely on the chassis where the chassis is metal; but with a 10mm foam or plastic spacer where the chassis is carbon fibre
 - positioned within 200mm of the road surface
 - not within 500mm of an LED light, it's cable or power source; and
 - not within 500mm of any Radio Frequency (RF) source (ie. fans or electric motors.)
- Transponders will be issued to Team Managers upon Check-in at the Administration Centre at the event.

MARKINGS

School Name

Each vehicle shall have their school name visibly displayed on either side of their vehicle.

Identification Panels

- Two Identification Panels will be issued to Team Managers upon Check-in at the Administration Centre at the event.
- The adhesive identification panels measure 250mm x 300mm and have the vehicle's competition number on it.
- These identification panels must be attached to each side of the tail of the vehicle and as close to the rear as possible.

Diagram 18.2: Positioning of number panel

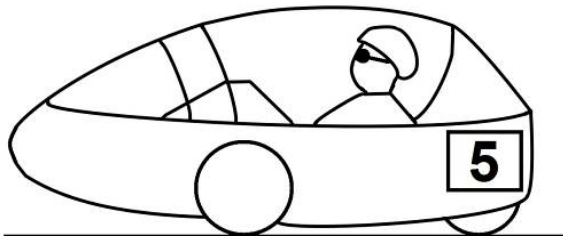

ENERGY EFFICIENT VEHICLES (EEVS) SUPPLEMENT

Version 2019.01

Introduction

- All specifications listed in the Human Powered Vehicle (HPV) And Energy Efficient Vehicles (EEV) Specifications apply to Energy Efficient Vehicles with the following additional specifications.
- This supplement should be read in conjunction with the HPV and EEV Specifications.
- Any significant specification changes from previous editions been highlighted and underlined in blue.
- **Key specifications that the Scrutineers wish to bring to the attention of Team Manager's have been highlighted in bold.**
- If changes are made to these specifications prior to the event, Team Managers will be notified via email and a new edition will be published on the website.
- The Energy Breakthrough (EB) Scrutineers have the final authority to decide if any vehicle or team participates in the event, based on safety and their interpretation of the following rules.
- All enquiries regarding HPV and / or EEV Specifications should be emailed to Lead Scrutineers Michael McTigue and Tim White via technical@eb.org.au

1 RIDER PROTECTION BARS

Rider protection for Energy Efficient Vehicles is the same as for Human Powered vehicles except that the metal protection bars are of greater diameter as per section 6.2 of the vehicle specifications.

Note:

A Human Powered Vehicle that has been converted to an Energy Efficient Vehicle will satisfy the Rider protection specifications by duplicating the minimum specified bar dimensions for an HPV.

FIRE EXTINGUISHER

- All Energy Efficient Vehicles must be fitted with an Australian Standard, dry powder minimum 5BE fire extinguisher of minimum capacity 0.5 kg.
- Fire extinguishers must be securely affixed to all Energy Efficient Vehicles. The use of weak or flimsy mounting brackets and/or securing straps is not permitted.
- Fire extinguishers must be positioned such that it can be readily reached and removed for use by either the rider from the normal riding position or external assistant in an emergency.
- The location of the fire extinguisher must be clearly indicated on the exterior of the vehicle.

ENGINE IMMOBILISER

- All Energy Efficient vehicles are required to fit a cut out switch that shuts down all propulsion sources and is accessible from outside the vehicle.
- The cut out switch must be clearly visible, marked by a blue triangle and mounted on the left hand side of the vehicle and within 300 mm of the rider's left shoulder.
- [This sticker will be issued to Team Managers upon Check-in at the Administration Centre at the event.](#)

POWER SOURCES

Number of Power Sources

There are three types of vehicle allowed in the Energy Efficient Vehicle category:

1. **Hybrid 1:** Pedal power, plus one other power source.
2. **Hybrid 2 (Open):** Two power sources, excluding pedal.
3. **Single Power Source:** Electric-only vehicles

Principle of Power Generation

- The fuel allocation is only available to vehicles fitted with internal combustion engines as one of their driving sources and will only be commercially available pump fuel as supplied from normal retail outlets.
- All fuel used for the trial will only be available from the Scrutineers.

Minimum Duration of Power Generation

- The machine must be capable of sustained operation when powered separately by each propulsion system.
- Pedal assist type vehicles will be eligible to compete in the Hybrid 1
- While satisfying this requirement a power source may be used intermittently during the event to overcome particular loads, such as starting from rest or hill climbing.
- The spirit of this clause is that a sacrificial form of propulsion is not acceptable.
- The test for whether a power source is compliant will be whether the vehicle is able to sustain its speed while driving on either power source on flat road.

ELECTRICALLY POWERED VEHICLES

Motor Type

Choice of motor type and gearing is free.

Total capacity and type of propulsion batteries

- Propulsion batteries shall be commercially available.
- Batteries and chargers must be labelled with the school name.
- Batteries will be marked during Scrutineering.

Battery Casing

- Batteries with deformed or damaged cases are not acceptable for use.

- Any Lithium Ion (Li Ion) batteries with thin plastic wrapping must be housed within a protective case at all times (on and off the vehicle including when charging) to prevent puncture or damage in an accident.
- This protective case must be made of non-conductive material and preferably made of hard-plastic case with a foam padding and a lead lock.
- Wet cell batteries must be housed in a sealed box (e.g. plastic) that will prevent spillage if the battery is inverted or damaged.

Figure Ref 5.3: Battery Casing Examples



Total combined mass of propulsion batteries

The maximum total combined mass of propulsion batteries per vehicle is:

Battery type	Kg
Lead Acid	80
Ni Cd	65
Li Po	20
Li Ion	20

Note: Where Lithium Ion or [Lithium Polymer](#) batteries are used a Battery Management System must be carried on board that is designed to provide adequate protection during charging and discharging.

Battery Charging Allowances

[In 2019, the amount of power available from the grid will be as follows:](#)

Pedal/electric EEV	7.0 kilowatt hours
Electric SPS EEV	12.0 kilowatt hours
Hybrid 2 Petrol/Electric	7.0 kilowatt hours

Mass of propulsion batteries on vehicle

- Vehicles are required to carry at least one battery pack at all times so that the electrical circuit is complete.
- Batteries must be securely mounted in vehicles.
- A battery pack is regarded as the normal quantity of batteries required for the electric motor to propel the vehicle.

Power limitations for EEV's:

- [Electrical systems are restricted to a maximum of 48 Volts.](#)
- [Hybrid 1 vehicles shall have an electric motor with a manufacturer's specification tag fitted. The maximum motor size is 400 watts.](#)
- [SPS and EEV 2 vehicles shall have an electric motor with a manufacturer's specification tag fitted. The maximum motor size is 750 watts.](#)
- All vehicles must be fitted with a maximum 20 Amp circuit breaker which must be mounted:
 - Out of reach of the rider.
 - In a position where it is visible to trial marshals when the vehicle is in the pits.

VEHICLES POWERED BY INTERNAL COMBUSTION ENGINES

Engine Type

Choice of engine type or gearing is free.

Fuel types

- Fuels for internal combustion engines will be commercially available pump fuels supplied by the organisers. (95 octane or less)
- Any team using a fuel other than premium unleaded petrol must notify The EB technical team prior to the end of October.
- Fuels which must be stored under pressure (ie. LPG, CNG and hydrogen) are not permitted.

Fuel tanks

Fuel tanks must be:

- of sufficient capacity to contain the entire fuel allocation for the vehicle for the Trial.
- securely mounted using a fixed retaining bracket on a structural component of the vehicle.
- shielded from the rider by the firewall (see section 7 Firewall, below).
- Fitted with a refilling cap (or any other tank closure) that shall be capable of having a mechanical seal (ie. wire cable-tie) applied to prevent unauthorised opening.

All fuel line connections must be secure and of an automotive standard.

Pressurised Fuel Systems

Pressurised fuel systems can be used (ie. diesel or petrol fuel injection) providing they comply with the following:

- all fuel lines are of a standard automotive type
- all fuel lines have crimped, or union type fittings at all ends
- all fuel lines must be securely mounted on the vehicle
- all fuel lines must be protected from heated sources and contact with any moving components

- any pressurised fuel tanks must have a relief valve that prevents pressure exceeding 10 psi and must be fitted with a metal, automotive tyre valve for testing.

FIREWALL

Description

Vehicle occupants must be separated and fully shielded (ie. no gaps) from any potential fire by a metal firewall.

This firewall must shield the rider from any direct flame occurring from:

- Engine and other high temperature heat sources.
- Fuel tank and lines
- Exhaust system

Firewall Dimensions

The firewall must extend in height:

Above fuel tank, fuel lines, exhaust system, engine and other heat sources or potential heat sources – as well as above the shoulders of the tallest vehicle occupant in the normal driving or riding position.

The firewall must extend downward:

To the floor line

The firewall must extend in width:

As wide as the rider's shoulders, in any case sufficiently to shield occupants from hot surfaces and potential fire sources.

Body panels must be kept clear of hot surfaces and fuel lines.

Exhaust

- Exhaust fumes, hot gases and vapours shall be routed to discharge clear of occupants and outside the bodywork, at the rear of the vehicle at a minimum angle to the horizontal of 45°, downward.
- An effective silencer shall be fitted to reduce noise, and the pipe must not protrude beyond the frame of the vehicle.
- The exhaust noise level must not exceed 90dB as measured behind the vehicle.

HPV, EEV AND TRY-ATHLON ENDURANCE TRIAL REGULATIONS

[Version 2019.01](#)

1 SPIRIT OF COMPETITION

The Energy Breakthrough Trial presents a unique opportunity for students to extend their learning experience beyond the boundaries of formal education. The following competition regulations have been framed so that the efforts and experiences of all participants are maximised, to be bound only by the constraints of safety and the spirit of healthy, but friendly competition.

2. ELIGIBILITY

2.1 Make-up of Teams

Teams will consist of the following numbers of competitors:

Class	Year Level	Team Size	Gender Requirements	School Size
A1	Years 1 - 6	Min 6 - Max 10	At least 50% female.	Schools with an enrolment of 200 or less
A2	Years 1 - 6	Min 6 - Max 10	At least 50% female.	Schools with an enrolment of more than 200.
B1	Years 7 - 8	Min 6 - Max 8	At least 50% female.	N/a
B2	Years 7 - 10	Min 6 - Max 8	At least 50% female.	N/a
C	Years 7 - 12	Min 6 - Max 8	At least 50% female.	N/a
All Female	Years 7 - 12	Min 6 - Max 8	Female only	N/a
Open	Up to Year 12	Min 6 - Max 8	No gender requirements.	N/a

2.2 Team composition

- All entries are to be team entries and must consist of current school students (Young people enrolled in a school or young people enrolled in a secondary school certificate/program and under 20 years of age as at 31 December).
- Team members do not have to all come from the same school. They could be part of a scout, church, or other community group, however they must all be current school students and be covered by the group's insurance. [Where non-school teams have riders from other schools participating in Energy Breakthrough, they must have written approval from the Principal of the school.](#)
- [Classification for schools entering the A1 and A2 classes will include the TOTAL school enrolment, not the Primary component of a school. This classification will be made by](#)

[the organisers using information published on each school's website and the MySchools website.](#)

2.3 Registered Riders

- Only registered team riders shall take part in the Trial, however rider changes can be made up to the start of the endurance trial.
- Emergency riders are encouraged to participate in the practice session to ensure they are familiar with the track and the vehicle.

2.4 Team Member Participation

- Team managers must ensure that every nominated team member participates as a rider during the Trial.
- Team Managers are required to keep a log of rider track time, which can be checked by marshals investigating incidents.

2.5 Age of Drivers

Drivers of Energy Efficient Vehicles shall be at least 14 years of age, unless special prior approval is provided by organisers.

2.6 Identification

All riders must have official identification, which must be shown on request during the trial.

2.7 Rider Substitution

- Sick or injured riders may be replaced prior to the start of the trial by a registered reserve rider of the same gender.
- Riders cannot be substituted after the start of the Trial.
- A rider substitution will require the identification wristband of the replaced rider to be handed to the Administration Centre and a new identification issued to the reserve rider.

3. RIDER ATTIRE

3.1 Fit and Adjustment

All vehicle occupants shall wear the following safety attire correctly fitted and adjusted at all times the vehicle is on the track during all on track activities..

3.2 Helmet

For human powered vehicles [and EEV 1 vehicles](#), minimum requirement is a bicycle helmet approved to AS 2063, AS 1698 or ECE 22.05.

For EEV 2 or electric-only Energy Efficient Vehicles, requirement is a motor cycle helmet approved to either AS 1698 or ECE 22.05.

3.3 Eye Protection

- [It is recommended that shatterproof glasses or cycling glasses be worn at all times.](#)
- [Vehicles that are fully enclosed are not required to wear eye protection.](#)
- Open bodywork (or 'head out') vehicles or vehicles have significant sections of windows removed will be required to wear eye protection.

3.4 Gloves

Gloves must be worn by riders when in the vehicle.

3.5 Shoes

Shoes must provide full foot coverage. Sandals or thongs are not permitted.

3.6 MP3 players

The use of MP3 players or similar music/entertainment devices by riders is NOT permitted during Trial or Practice sessions.

3.7 Video cameras

- Small video cameras (eg. GoPro) are allowed as long as they are not attached to the rider's helmet and do not pose any safety risk.
- Camera's must not be mounted to the outside of the vehicle silhouette when viewed from the front

3.8 Clothing

Human Powered Vehicles

- Minimum coverage of shoulders, upper body and mid-thigh (e.g.: shorts and T-shirt; or cycling knicks and jersey.)
- Sleeveless triathlon skin suits, sleeveless cycling jerseys, sleeveless t-shirts, tank tops or singlets are not permissible.

Electric powered Energy Efficient Vehicles

- Riders of pedal/electric hybrid vehicles may choose to comply with the Human powered Vehicle clothing rules.
- Riders of electric-only vehicles must comply with the requirements for liquid fuelled vehicles below.
- Teams that have battery power must provide a pair of full cover gloves and a pair of protective goggles for anyone handling batteries.

Liquid-fuelled Energy Efficient Vehicles

- All riders shall wear overalls or clothes that cover and are neat fitting from ankle to wrist to neck.
- Fire retardant material is advised and light fabric / disposable overalls are not permitted
- It is not permissible for riders of fuel powered vehicles to 'dress down' when their fuel is used up.

4. SCRUTINEERING

4.1 Compulsory

Scrutineering is compulsory for all vehicles and teams, to ensure compliance with vehicle specifications and safety requirements.

4.2 Before track

- Before entering onto the track for a Practice session, all vehicles must be scrutineered for safety.
- Scrutineers can refuse permission to enter the track for any safety reason.

4.3 Subsequent scrutineering

All vehicles may also be inspected at random during the trial for operation of safety items or when the vehicle is involved in a track incident. (See Section 7.11).

TRAFFIC LIGHTS, FLAGS AND SIGNALS

All competitors shall understand the meaning of the following traffic signals/flag signals:

Green Light or Flag

The track is clear for competition.

Yellow Light or Flag

- A sign of danger or track obstruction in the vicinity of the marshal point.
- Riders are required to stop racing, slow and pass the point of danger at a significantly reduced speed (at or below 20 kph) using extreme caution
- Riders must not resume competition until they are well clear of the danger and until they reach the vicinity of the next marshal point displaying a Green Light or Flag.

Red Light or Flag

- An indication of extreme danger.
- All vehicles shall come to an immediate stop.
- Racing has ceased.
- Riders must follow the directions of the Clerk of Course and flag marshals.

Blue Flag

- Is an indicator that a faster vehicle is positioned close to you.
- Competitors shown the blue flag must hold their line to allow overtaking.

TRANSPONDERS AND LAP TIMING

It is the Team Manager's responsibility to ensure that:

- a transponder is collected from the Administration Centre at Check-in;
- the transponder is correctly fitted to the vehicle according to the instructions;
- the transponder is working during all on track activities;
- [any queries relating to lap times are reported to Timing Officials as soon as practical for investigation; and](#)
- the transponder is returned to the Administration Centre at the end of the Trial, prior to leaving the event site.

START, FINISH AND BREAK

Pre-Trial Briefing

All Team Managers must attend the pre-trial briefing by the Clerk of Course and / or Trial Director.

Grid Assembly

- The Trial Director, in conjunction with the marshal team, will allocate and advertise starting grid positions following the practice session.
- Vehicles will be assembled according to the official grid positions.
- Vehicles will be called to the starting grid assembly area [60 minutes](#) prior to the official start.

- If a vehicle is not on the grid within 15 minutes of the scheduled start time, officials reserve the right to place the vehicle at the rear of the grid.

Trial Start

The trial will be started with the drop of the National flag.

Trial Finish

All trials will conclude with the display of the black and white chequered flag.

This is will be:

- 24 hours after the start for the secondary HPV and Energy Efficient Vehicle teams.
- After 14 hours of competition for the HPV Class A teams.
- 8 hours after the start for TRYathlon teams in their Endurance Trial.
- After all 8 riders have completed the TRYathlon Obstacle and TRYathlon Time Trial events.

Primary break

- All HPV A vehicles will leave the track by re-entering the pits from the time specified in the event schedule on Friday evening.
- All HPV A teams will restart their trial at the specified time on Saturday morning.
- The restart of the HPV A trial will be under the direction of the Clerk of Course.

Extreme Weather (Heat / Rain)

In the event of severe heat exceeding 36 degrees or severe rain / thunderstorm or other severe weather events, the Clerk of Course and / or Trial Director reserve the right to implement a range of staged strategies to reduce risk to riders, marshals, support crew and spectators on site.

These strategies range from compulsory breaks for riders, suspension of the Trial for a period of time, to cancellation of the Trial.

TRACK CONDUCT

Speed Limit

- Speedometers are mandatory and ALL competing vehicles shall observe a maximum speed of 60 km/h during all on track activities.
- The maximum speed in the pit lane is 10 km/h.
- Vehicles detected exceeding 60km/h will have the lap immediately voided.
- Voided laps will be displayed on the results display system, but not counted towards a team's final total.

Seat belts

All vehicle occupants shall wear a correctly adjusted seat belt during all on track activities.

(Refer 8.4 of the Vehicle Specifications for correct adjustment of seat belts.)

Right of Way

Competing vehicles have right of way over disabled vehicles that need to be recovered.

Direction of Travel

Under no circumstances is a vehicle to be ridden or pushed on the track in the opposite direction to competition.

Track Position and Overtaking

- A blue line has been painted on the track. Riders should keep to the left of this blue line on the inside of the track, unless overtaking another vehicle.
- Riders should overtake on the outside, to the right of the vehicle being overtaken.
- Riders should not change lanes without checking their mirrors to make sure it is safe to do so.
- It is the responsibility of the overtaking (faster) rider to ensure that the overtaking move is carried out without endangering other competitors.
- Cutting in, deliberate blocking or leaving insufficient clearance will be penalised.

Vehicle Lighting

- Front lights, as per by Vehicle Specifications, shall be illuminated during the hours of darkness as directed by the Clerk of Course.
- Rear lights, as per by Vehicle Specifications, are to be turned on steady mode during all on track activities.
- Riders must stop in the pits as soon as possible to rectify any inoperable or insecure lights.

Lighting Batteries

Batteries used solely for lighting may be charged and/or recharged and/or replaced as required.

Track Incidents

- All vehicles involved in significant crashes or rollovers are to be removed from the track by marshals only and the barriers quickly restored to trial condition as soon as practical.
- All vehicles involved in rollovers or significant crashes must have a "Return to Pits" sticker applied and may then be ridden back to the pits.
- Vehicles that have been involved in a track incident and received a "Return to Pits" sticker cannot restart until a Pit Marshal has checked the vehicle is safe to continue and have removed the sticker.
- [After returning to the pits the rider will NOT be allowed to ride again for at least 30 Minutes.](#) During this time, Team Managers must monitor the riders' condition, and if in doubt take the rider to the Trackside Medical Centre for assessment.
- If a vehicle is unable to continue because it is damaged or the rider is unable to ride, then the vehicle may be recovered by the team for repair. Teams unable to recover their own vehicle can request assistance.
- Riders who are unable to ride their vehicle back to the pits should be taken to the Trackside Medical Centre to be assessed. They must be cleared by the medical team before being allowed to ride again.

Injured Riders

The Clerk of Course and track marshals monitor the all on track activity and where necessary will call for assistance from Medical and Emergency Services to attend to injured riders.

Vehicle Recovery

- If a vehicle breaks down, the track marshals will report the incident and the team will be informed.
- It is the responsibility of the team to recover their vehicle.
- If a team is unable to safely recover their vehicle they can request assistance from the Clerk of Course and event officials.

Emergency Vehicles

- When emergency vehicles are on the track it displays flashing yellow lights which indicates extreme danger in the same manner as corner yellow lights/flags.
- Riders must slow down, use extreme caution, must not overtake other competitors and pass when directed by the officials.

PIT AREAS

Pit Set-up

- All pit sites must be set-up as per the direction of Event Officials.
- Each team in the HPV, EEV and TRYathlon endurance trials will be allocated a site in the pit area, except where schools with three entries in a category will be allocated two pits sites.
- All pit sites are numbered and are a minimum of 2.8 metres wide by 2.0 metres deep.
- Where possible, pit numbers are the same as the team number.
- All teams must leave approx 1 metre clearance area in front of their pit site for rider changeovers and for other teams to have line of sight of the track and pit lane.
- There is no existing shelter in the Pit areas.
- Teams are encouraged to erect a small tent or arrange to share a tent with another team.
- Teams are encouraged to erect a team or school banner in their designated pit area(s) including team numbers. A banner about two by one metres would be ideal.
- HPV A teams are required to share their pit spaces - but not tools and resources - with Try-athlon teams for their Friday night Try-athlon Practice session.
- No vehicles or trailers will be allowed in the Try-athlon pit areas.

Speed in Pits

Maximum speed in the pit area is 10 km/h.

Direction of Travel in Pits

Under no circumstances shall a vehicle enter the pit area via the pit exit lane.

Pit Lane Conduct

- All rider changes shall occur in the designated area adjacent to each team's pit.
- Closed shoes must be worn in pit lane.
- Vehicles shall come to a halt in the pit lane under the effect of the vehicle's own braking system.
- Stopping with the assistance of others is not permitted.
- Rider shall bring their vehicle to a complete stop prior to unfastening seat belts.
- Rider refreshments and adjustments to clothing etc. shall only be effected when the vehicle is stationary in the pit area.

- A maximum of three students and one supervising adult, in addition to the incoming and outgoing riders, shall attend a vehicle in the pit lane at rider change-over.
- The four designated people from each team attending the vehicle in pit lane are encouraged to wear a reflective vest and must wear enclosed shoes.
- Pit entry and exit lanes shall be kept clear at all times.
- Stationary vehicles shall give way to vehicles proceeding along pit lane.

Pit Crew Communications

- The use of radio communication between rider and pit crew is permitted provided operating the unit does not interfere with the rider's control of the vehicle.
- The use of notice boards for communication between the rider and the pit crew are permitted.
- However, such notice boards and their use shall comply with the following:
 - they must be held and displayed by one person only at a time;
 - they must be held so they do not go beyond the line of pit lane barriers.

Major Repairs

- Major repairs including welding and grinding equipment must NOT be carried out in the pit lane. The pit lane includes a team's tent adjacent to the track.
- These repairs must be carried out in the vicinity of the repair container.

Removal of Components

- Redundant, superfluous and/or damaged components of substantial mass (i.e. greater than 0.5 kg) may not be removed from a vehicle except with the permission of the Clerk of Course.
- At the discretion of the Clerk of Course, the vehicle may be required to carry ballast.
- Teams may not substitute or replace power sources or strip the vehicle below its starting weight after the commencement of the event.

FUEL USE AND RECHARGING OF BATTERIES

Fuel Burning Energy Efficient Vehicles

In accordance with the EEV Vehicle specifications, fuel burning entries will receive a single allocation of fuel.

Amounts of Fuel Allocated

[EEV1 Petrol + Pedal: 2 litres](#)

EEV2 Petrol + Electric: 3 litres

Sealing of Fuel Tanks

Fuel tanks on vehicles will be sealed after the allocation of fuel prior to the start of the event.

Batteries

- At EEV teams using batteries are required to present all of their battery allocation for identification marking at scrutineering.

- All batteries must have manufacturers labels including details of battery type displayed.
- Batteries must be labelled with the school name.

Battery Recharging – Processes and Procedures

- The onus is on the teams to use safe and reliable battery chargers.
- Teams will start the Trial with fully charged batteries.
- All recharging is to be conducted in a designated area provided by the event organisers, and under constant supervision, to ensure charging is carried out in a safe manner.
- The designated recharging area will not open until one hour after the trial start.
- [Batteries must be signed in and out via the designated marshal on duty at the time.](#)
- Any team found to be charging batteries not in the designated area will be penalised.
- All battery chargers must be electrically tested and tagged. Only approved tagged chargers can be used.
- Chargers must also be presented during Scrutineering for an extra Energy Breakthrough tag to be applied.
- Battery chargers must be of a commercially available type.
- The physical dimensions of the charger must not exceed 300 mm x 300 mm x 300 mm
- Bare connections and alligator clips are strictly forbidden. All connections must be made using a properly insulated electrical connector. Anderson plugs are the preferred type of connector.
- Only one battery pack may be charged at a time. A battery pack is defined as the usual amount of batteries required to run the vehicle.
- [Teams will be provided with one power outlet in the charging area, which will be fitted with a digital readout.](#)
- [Outlets are restricted to 4 amps \(fused\) or 720W whichever is the lower and officials will disconnect chargers drawing higher amp readings and notify the team.](#)
- [Once kilowatt hour allocation has been used, the power outlet will shut off. Teams must remove their charging equipment from the container at this point.](#)

TRIAL POINT SCORING

- The vehicle completing the greatest number of laps in each class in the Trial period scores the maximum points.
- Other vehicles in each class score points for the number of laps completed in proportion to the number of laps.
- In HPV Secondary, HPV Primary and EEV classes, the Endurance trial is worth 50 points.
- In TRYathlon, the Endurance is worth 30 points.

For example, say team AA in a particular class travels the greatest distance, 200 laps, and team BB in the same class travels 160 laps.

Points scored are as follows:

Team AA: 200 laps = 50 points

Team BB: 160 laps 50 x $\frac{160}{200}$ = 40 points

INFRINGEMENTS

Vehicle Design

- Vehicles which are considered safe but DO NOT comply with key elements of vehicle specifications may be given permission to start the trial with a penalty.
- This penalty can be up to 50 laps and will be applied by the event officials.

Reporting of Incidents and Timing Issues

- Teams may report track incidents or infringements of these competition rules to the Clerk of Course or Pit Marshals who will investigate and act accordingly.
- [Any queries relating to lap timing issues are to be reported to the Timing Officials as soon as practical for investigation.](#)
- [Where the Timing Officials believe there is a lap timing issue requiring correction, all such corrections shall be coordinated through the Clerk of Course or Trial Director.](#)

Protests

- Teams who wish to proceed with a formal protest will be provided with the appropriate documentation via the Clerk of Course.

Penalties

- A team that breaches any trial regulation including the spirit of competition, will be notified that they are under investigation for an infringement of the competition rules.
- The Clerk of Course and event officials will review the incident and may apply a penalty which they consider is consistent with the severity and intent of the infringement.
- Incident reviews will be conducted as soon as practical, but in any case, will be resolved before the end of the endurance trial.

Penalties may take the form of:

- A warning.
- A “stop and go” penalty.
- A time penalty.
- 50 lap penalty.
- Disqualification of a rider.
- Exclusion from trial results.
- Withdrawal from competition.



CIRCUIT LENGTHS
 TRACK 1 - 1.58 km
 VICROADS - 1.11 km

KEY

- Toilets
- Showers
- Camping Area
- First Aid
- Food & Refreshments
- Assembly Point
- Marshall Point & Number
- Track Direction
- Start/Finish
- Pushcart Changeover Point
- Wrist Banding Station
- Repair Station
- Recharge Station
- Parking Area
- On-site Supermarket
- Hospitality Marquee
- Stage #1
- VicRoads Stage
- Road Closure

Map not to scale